

J E T

ZX Series

METALWORKING LATHE

**3219XXT
400/50/3**

**PARTS LIST
ERSATZTEILLISTE
LISTE DE PIECES**

WMH Tool Group AG

Bahnstrasse 24, CH – 8603 Schwerzenbach
www.wmhtoolgroup.ch; info@wmhtoolgroup.ch
Tel +41 (0) 1 806 47 48
Fax +41 (0) 1 806 47 58

P-3219XXT 05/03



Table of Contents

| | |
|--|-------|
| Table of Contents | 1 |
| Stand Assembly | 2-4 |
| Brake Assembly | 5-6 |
| Bed Assembly | 7-9 |
| Headstock Assembly I..... | 10-12 |
| Headstock Assembly II..... | 13-15 |
| Headstock Assembly III..... | 16-17 |
| Headstock Assembly IV | 18-19 |
| Change Gear Box Assembly I..... | 20-21 |
| Change Gear Box Assembly II..... | 22-23 |
| Quick Change Gear Box I | 24-26 |
| Quick Change Gear Box II | 27-28 |
| Quick Change Gear Box III | 29-30 |
| Apron Assembly I | 31-33 |
| Apron Assembly II | 34-36 |
| Apron Assembly III | 37-38 |
| Carriage Assembly..... | 39-41 |
| Carriage Stop Assembly | 42-43 |
| Four Way Tool Post | 44-45 |
| Tailstock Assembly I | 46-47 |
| Tailstock Assembly II | 48-49 |
| Steady Rest Assembly | 50-51 |
| Follow Rest Assembly..... | 52-53 |
| Coolant And Work Light Assembly | 54-55 |
| Micro Carriage Stop Assembly | 56 |
| Other Parts..... | 57 |
| Electrical Cabinet | 58 |
| Wiring Diagram | 59 |
| Protecting guards for three rods | 60 |
| Safety guard cover | 61 |

Stand Assembly

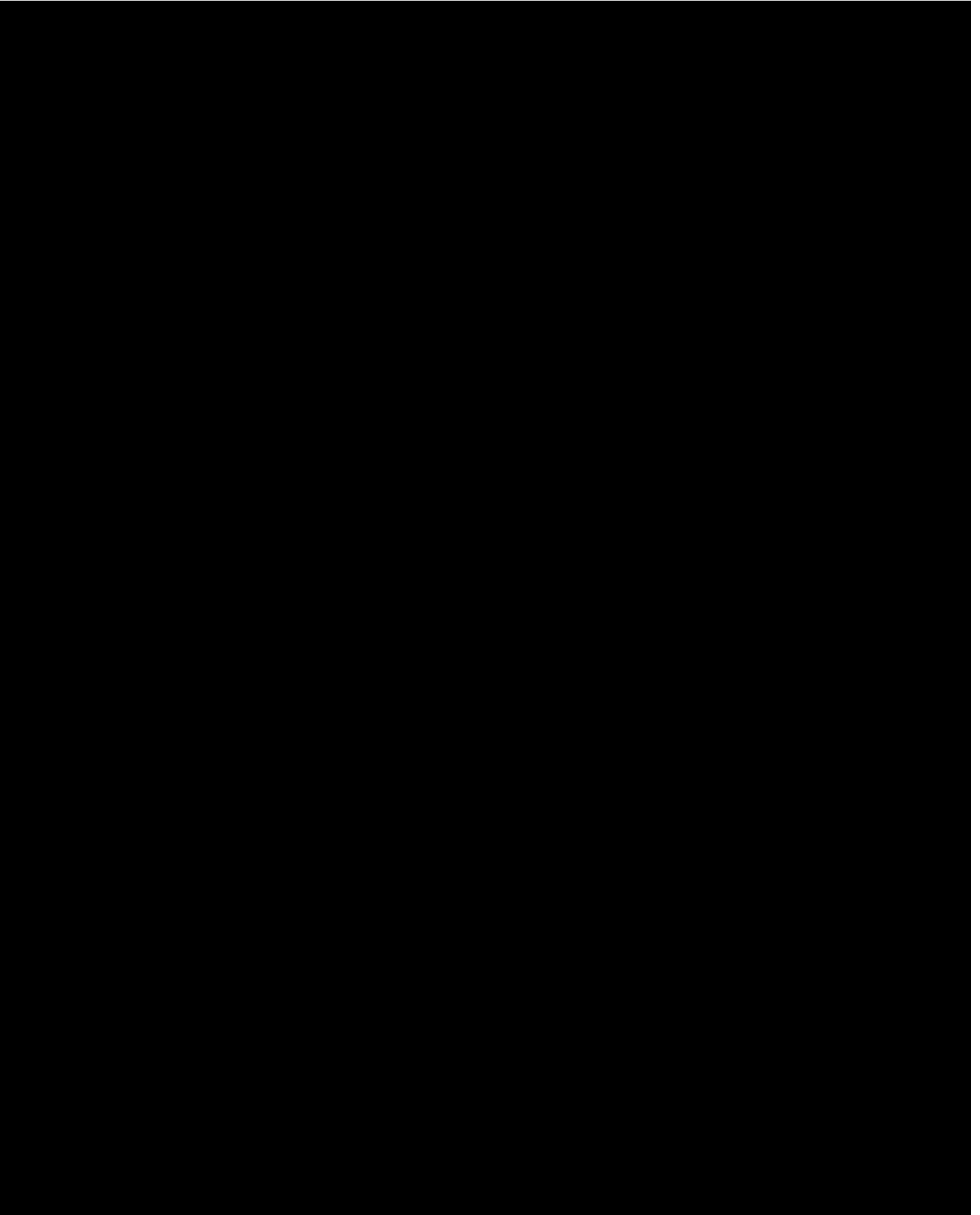

Stand Assembly

| Index No. | Part No. | Description | Size | Qty. |
|-----------|------------|---|----------------|------|
| 1 | ZX-01101A | Pulley | | 1 |
| 2 | ZX-S2 | Cylindrical End Set Screw | M8x16 | 1 |
| 3 | ZX-01734 | Cover | | 1 |
| 4 | ZX-S4 | Cross Head Screw | M6x14 | 4 |
| 5 | ZX-S2 | Cylindrical End Set Screw | M8x16 | 1 |
| 6 | ZX-01701 | Pedal Rod Support | | 1 |
| 7 | ZX-01715 | Lining | | 6 |
| 8 | TS-1540231 | Hex Nut | M24x2 | 6 |
| 9 | ZX-01712 | Hex Cap Bolt | | 3 |
| 9A | ZX-01713 | Hex Cap Bolt | | 3 |
| 10 | ZX-01102A | Bed Stand (for 40" models, serial # 010611ZX349 and lower) | | 1 |
| | ZX-01102AN | New Bed Stand (for 40" models, serial # 010618ZX350 and higher) | | 1 |
| | ZX-01102B | Bed Stand (for 60" models, serial # 010611ZX349 and lower) | | 1 |
| | ZX-01102BN | New Bed Stand (for 60" models, serial # 010618ZX350 and higher) | | 1 |
| | ZX-01102C | Bed Stand (for 1880ZX, serial # 010611ZX349 and lower) | | 1 |
| | ZX-01102CN | New Bed Stand (for 1880ZX, serial # 010618ZX350 and higher) | | 1 |
| 11 | ZX-01703 | Fixed Support | | 2 |
| 12 | TS-1514021 | Socket Head Cap Screw | M6x14 | 4 |
| 13 | ZX-S13 | Taper Pin | 5x20 | 2 |
| 14 | ZX-01705 | Water Leaking Chip Guard | | 1 |
| 15 | ZX-S15A | Cross Head Screw | M5x20 | 4 |
| 16 | TS-1540121 | Hex Nut | M20 | 9 |
| 17 | ZX-01702 | Bolt | | 3 |
| 18 | TS-1550111 | Washer | A20 | 6 |
| 19 | ZX-01122A | Motor Mounting Plate (for 14" models) | | 1 |
| | ZX-01122B | Motor Mounting Plate (for 16"/18" models) | | 1 |
| 20 | ZX-01726 | Cover | | 1 |
| 21 | ZX-S4 | Cross Head Screw | M6x14 | 4 |
| 22 | ZX-S22 | Key | 10x8x70 | 1 |
| 23 | ZX-S23A | Main Motor (for 14" models) | 7.5HP, 4P, 3Ph | 1 |
| | ZX-S23B | Main Motor (for 16"/18" models) | 7.5HP, 6P, 3Ph | 1 |
| 24 | ZX-017609A | Wire Conduit (for 1440/1640/1840ZX) | | 1 |
| | ZX-017609B | Wire Conduit (for 1460/1660/1860ZX) | | 1 |
| | ZX-017609C | Wire Conduit (for 1880ZX) | | 1 |
| 25 | ZX-01708 | Wire Conduit Support | | 1 |
| 26 | ZX-01706 | Locking Plate | | 1 |
| 27 | ZX-S27 | Cross Head Screw | M5x8 | 2 |
| 28 | ZX-S15 | Cross Head Screw | M4x6 | 1 |
| 29 | ZX-01711 | Water Reception Plate | | 1 |
| 30 | ZX-S4 | Cross Head Screw | M6x14 | 2 |
| 31 | ZX-01510 | Coolant Tank | | 1 |
| 32 | ZX-01714 | Cover | | 1 |
| 33 | ZX-S4 | Cross Head Screw | M6x14 | 6 |
| 34 | ZX-S34 | Nut | M3 | 4 |
| 35 | ZX-S35 | Coolant Indicator | | 1 |
| 36 | ZX-S36 | Cross Head Screw | M3x20 | 4 |
| 37 | TS-1540072 | Hex Nut | M10 | 4 |
| 38 | TS-1550071 | Washer | M10 | 4 |
| 39 | TS-1491041 | Hex Cap Bolt | M10x30 | 4 |
| 80 | ZX-01716A | Stand Front Cover (for 1440/1640/1840ZX) | | 1 |
| | ZX-01716B | Stand Front Cover (for 1460/1660/1860ZX) | | 1 |
| | ZX-01716C | Stand Front Cover (for 1880ZX) | | 1 |
| 81 | ZX-01501 | Gasket | | 1 |
| 82 | ZX-S82 | Hex Nut | M5 | 2 |
| 83 | ZX-01740 | Left Tray | | 1 |
| 84 | ZX-01741 | Right Tray | | 1 |

| Index No. | Part No. | Description | Size | Qty. |
|------------------|-----------------|-----------------------------|-------------|-------------|
| 85 | ZX-01511 | Gasket | | 2 |
| 86 | ZX-S86 | Cross Head Screw | M5x16 | 6 |
| 87 | ZX-01512 | Gasket | | 1 |
| | JX21004 | Terminal Board (not shown) | | 1 |
| | 18301 | Junction Box (not shown) | | 1 |
| | D97-4 | Plastic Fitting (not shown) | | 1 |
| 88 | ZX-05753 | Extending Plate | | 1 |

Brake Assembly

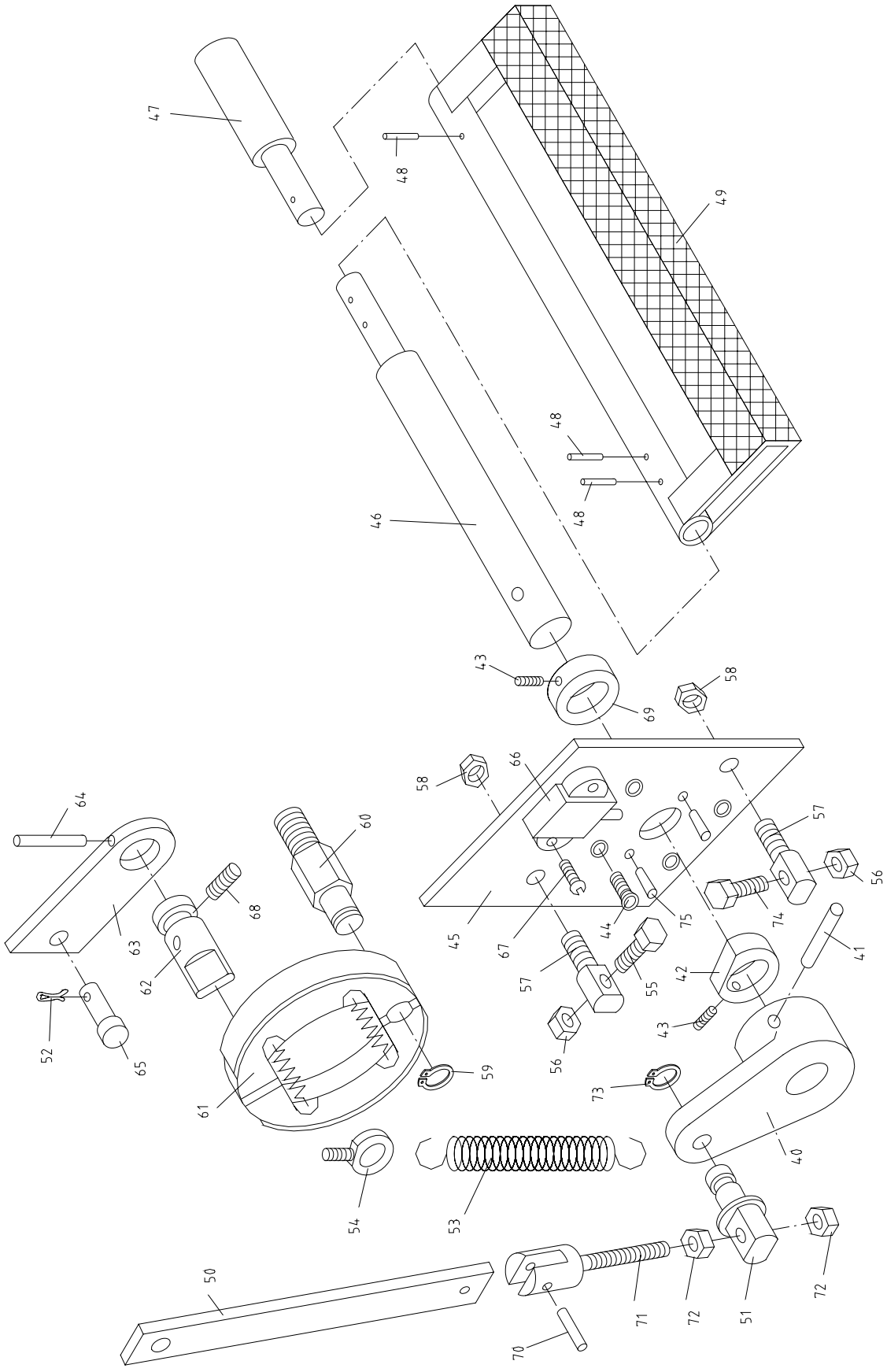

Brake Assembly

| Index No. | Part No. | Description | Size | Qty. |
|-----------|------------|------------------------------|------------|------|
| 40 | ZX-22101 | Fork | | 1 |
| 41 | ZX-S41 | Spring Pin | 5x40 | 1 |
| 42 | ZX-22703 | Butt Nail Support | | 1 |
| 43 | TS-1524021 | Set Screw | M8x10 | 1 |
| 44 | ZX-S44 | Cross Head Screw | M5x20 | 4 |
| 45 | ZX-22714 | Positioning Plate | | 1 |
| 46 | ZX-22704A | Driving Shaft-Longer | | 1 |
| 47 | ZX-22705A | Driving Shaft | | 1 |
| 48 | ZX-S48 | Spring Pin | 5x30 | 3 |
| 49 | ZX-22712A | Pedal (for 1440/1640/1840ZX) | | 1 |
| | ZX-22712B | Pedal (for 1460/1660/1860ZX) | | 1 |
| | ZX-22712C | Pedal (for 1880ZX) | | 1 |
| 50 | ZX-22710A | Draw Bar (for 14" models) | | 1 |
| | ZX-22710B | Draw Bar (for 16" models) | | 1 |
| | ZX-22710C | Draw Bar (for 18" models) | | 1 |
| 51 | ZX-22706 | Connecting Shaft | | 1 |
| 52 | ZX-S52 | Split Pin | 2x20 | 2 |
| 53 | ZX-S53 | Tensile Spring | 3.5x26x190 | 1 |
| 54 | ZX-S54 | Eyebolt | M8 | 1 |
| 55 | TS-1490091 | Hex Cap Bolt | M8x50 | 1 |
| 56 | TS-1540061 | Hex Nut | M8 | 1 |
| 57 | ZX-22707A | Butt Rod Support | | 1 |
| 58 | TS-1540072 | Hex Nut | M10 | 1 |
| 59 | ZX-S59 | C-Clip | 8 | 1 |
| 60 | ZX-22701 | Positioning Shaft | | 1 |
| 61 | ZX-S61 | Brake Shoe | | 1 |
| 62 | ZX-22702 | Brake Shaft | | 1 |
| 63 | ZX-22708 | Connecting Plate | | 1 |
| 64 | ZX-S64 | Elastic Pin | 5x25 | 1 |
| 65 | ZX-22709 | Connecting Shaft | | 1 |
| 66 | ZX-S66 | Stroke Switch | | 1 |
| 67 | ZX-S67 | Screw | M4x25 | 2 |
| 68 | ZX-S68 | Cylindrical End Set Screw | M5x10 | 1 |
| 69 | ZX-22711 | Butt Nail Support | | 1 |
| 70 | ZX-S70 | Pin | 5n6x20 | 1 |
| 71 | ZX-22715 | Adjust Bolt | | 1 |
| 72 | TS-1540061 | Hex Nut | M8 | 1 |
| 73 | ZX-S73 | C-Clip | 12 | 2 |
| 74 | ZX-S74 | Hex Cap Bolt | M8x35 | 1 |
| 75 | ZX-S75 | Taper Pin | 5x20 | 2 |

Bed Assembly

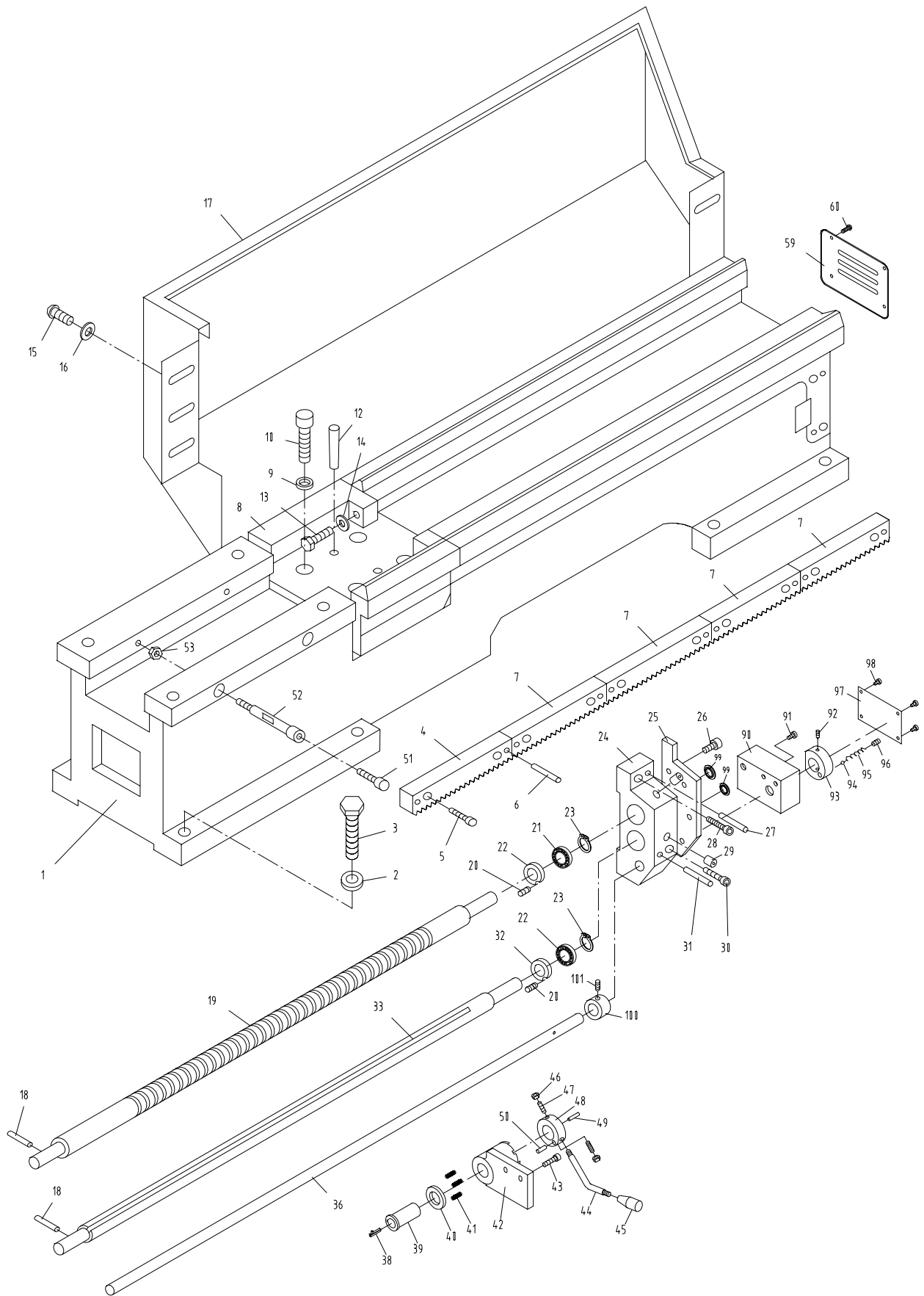

Bed Assembly

| Index No. | Part No. | Description | Size | Qty. |
|-----------|------------|--|----------|------|
| 1 | ZX-01104A | Bed (for 1440/1640/1840ZX) | | 1 |
| | ZX-01104B | Bed (for 1460/1660/1860ZX) | | 1 |
| | ZX-01104C | Bed (for 1880ZX) | | 1 |
| 2 | TS-1550101 | Washer | B16 | 8 |
| 3 | ZX-B3 | Hex Cap Bolt | M16x50 | 8 |
| 4 | ZX-01706 | Rack | | 1 |
| 5 | TS-1516041 | Hex Socket Cap Screw (for 1440/1640/1840ZX) | M10x35 | 10 |
| | | Hex Socket Cap Screw (for 1460/1660/1860ZX) | M10x35 | 14 |
| | | Hex Socket Cap Screw (for 1880ZX) | M10x35 | 18 |
| 6 | ZX-B6 | Taper Pin (for 1440/1640/1840ZX) | 8x50 | 10 |
| | | Taper Pin (for 1460/1660/1860ZX) | 8x50 | 14 |
| | | Taper Pin (for 1880ZX) | 8x50 | 18 |
| 7 | ZX-01706A | Rack (for 1440/1640/1840ZX) | | 4 |
| | | Rack (for 1460/1660/1860ZX) | | 6 |
| | | Rack (for 1880ZX) | | 8 |
| 8 | ZX-01112 | Saddle | | 1 |
| 9 | TS-1551081 | Lock Washer | 12 | 4 |
| 10 | TS-1517041 | Hex Socket Cap Screw | M12x55 | 4 |
| 12 | ZX-B12 | Thread Taper Pin | 12x70 | 2 |
| 13 | TS-1491101 | Hex Cap Bolt | M10x55 | 2 |
| 14 | TS-1550071 | Washer | M10 | 2 |
| 15 | TS-1503021 | Hex Socket Cap Screw | M6x10 | 6 |
| 16 | TS-1550041 | Washer | M6 | 6 |
| 17 | ZX-01741A | Splash Guard (for 1440ZX) | | 1 |
| | ZX-01741B | Splash Guard (for 1460ZX) | | 1 |
| | ZX-01741C | Splash Guard (for 1640ZX) | | 1 |
| | ZX-01741D | Splash Guard (for 1660ZX) | | 1 |
| | ZX-01741E | Splash Guard (for 1840ZX) | | 1 |
| | ZX-01741F | Splash Guard (for 1860ZX) | | 1 |
| | ZX-01741G | Splash Guard (for 1880ZX) | | 1 |
| 18 | ZX-B18 | Shear Pin | 5x35 | 2 |
| 19 | ZX-01708A | Lead Screw (for 40" models, Serial # 010611ZX349 and lower) | | 1 |
| | ZX-01708AN | New Lead Screw (for 40" models, Serial # 010618ZX350 and higher) | | 1 |
| | ZX-01708B | Lead Screw (for 60" models, Serial # 010611ZX349 and lower) | | 1 |
| | ZX-01708BN | New Lead Screw (for 60" models, Serial # 010618ZX350 and higher) | | 1 |
| | ZX-01708C | Lead Screw (for 1880ZX, Serial # 010611ZX349 and lower) | | 1 |
| | ZX-01708CN | New Lead Screw (for 1880ZX, Serial # 010618ZX350 and higher) | | 1 |
| 20 | ZX-B20 | Flat End Set Screw | M6x10 | 2 |
| 21 | ZX-01109 | Sleeve (serial # 010611ZX349 and lower) | | 1 |
| | ZX-01109N | New Sleeve (serial # 010618ZX350 and higher) | | 1 |
| 22 | ZX-1204 | Double Row Spherical Ball Bearing | 20x47x14 | 2 |
| 23 | ZX-B23 | C-Clip | 20 | 2 |
| 24 | ZX-01110 | Bracket (serial # 010611ZX349 and lower) | | 1 |
| | ZX-01110N | New Bracket (serial # 010618ZX350 and higher) | | 1 |
| 25 | ZX-01111 | Cover | | 1 |
| 26 | TS-1514021 | Hex Socket Cap Screw | M6x14 | 4 |
| 27 | ZX-B27 | Taper Pin | 6x60 | 1 |
| 28 | TS-1516061 | Hex Socket Cap Screw | M10x50 | 1 |
| 29 | ZX-B29 | Oil Cup | 10 | 2 |
| 30 | TS-223991 | Hex Socket Cap Screw | M10x100 | 1 |
| 31 | ZX-B31 | Taper Pin | 6x100 | 1 |
| 32 | ZX-01108 | Sleeve (serial # 010611ZX349 and lower) | | 1 |
| | ZX-01108N | New Sleeve (serial # 010618ZX350 and higher) | | 1 |
| 33 | ZX-01709A | Feed Rod (for 40" models, serial # 010611ZX349 and lower) | | 1 |
| | ZX-01709AN | New Feed Rod (for 40" models, serial # 010618ZX350 and higher) | | 1 |
| | ZX-01709B | Feed Rod (for 60" models, serial # 010611ZX349 and lower) | | 1 |

| Index No. | Part No. | Description | Size | Qty. |
|-----------|---------------|--|---------|------|
| | ZX-01709BN | New Feed Rod (for 60" models, serial # 010618ZX350 and higher) | | 1 |
| | ZX-01709C | Feed Rod (for 1880ZX, serial # 010611ZX349 and lower) | | 1 |
| | ZX-01709CN | New Feed Rod (for 1880ZX, serial # 010618ZX350 and higher) | | 1 |
| 36 | ZX-01707A | Control Rod (for 1440/1640/1840ZX) | | 1 |
| | ZX-01707B | Control Rod (for 1460/1660/1860ZX) | | 1 |
| | ZX-01707C | Control Rod (for 1880ZX) | | 1 |
| 37 | TS-1540031 | Nut | M5 | 1 |
| 40 | ZX-06001C-2 | Spacer | | 1 |
| 41 | ZX-B41 | Spring | 1x75x25 | 3 |
| 42 | ZX-06001C-1 | Bracket | | 1 |
| 43 | TS-1515011 | Hex Socket Cap Screw | M8x16 | 2 |
| 44 | ZX-B44 | Lever | | 1 |
| 45 | ZX-06001C-4 | Long Lever Sleeve | | 1 |
| 46 | ZX-B46 | Hex Nut | M8 | 2 |
| 47 | ZX-B47 | Set Screw | M8x28 | 2 |
| 48 | ZX-06001C-5 | Direction Change Ring | | 1 |
| 49 | ZX-B49 | Pin | 8n6x20 | 1 |
| 50 | ZX-B50 | Taper Pin | 3x20 | 1 |
| 51 | TS-1516061 | Hex Socket Cap Screw | M10x48 | 2 |
| 52 | ZX-05741 | Threaded Tube | | 2 |
| 53 | TS-1540081 | Hex Nut | M12 | 2 |
| 59 | ZX-01715C | Cover | | 1 |
| 60 | ZX-B60 | Cross Recessed Pan Head Screw | M6x18 | 4 |
| 61 | TS-1482031 | Hex Cap Bolt | M6x16 | 2 |
| 62 | ZX-B62 | Pin | 2x15 | 2 |
| 63 | ZX-01719 | Rocker | | 1 |
| 90 | C0632A-01301E | Switch Box | | 1 |
| 91 | ZX-B91E | Hex Socket Cap Screw | M8x20 | 4 |
| 92 | ZX-B92E | Screw | M6x16 | 1 |
| 93 | Co632A-01705E | Bushing | | 1 |
| 94 | ZX-B94E | Steel Ball | 6 | 1 |
| 95 | ZX-B95E | Spring | | 1 |
| 96 | ZX-B96E | Screw | M8x16 | 1 |
| 97 | Co632A-01504E | Switch Box Cover | | 1 |
| 98 | ZX-B98E | Hex Socket Cap Screw | M5x10 | 4 |
| 99 | Co632A-01503E | Plug | | 2 |
| 100 | ZX-01706E | Positioning Sleeve | | 1 |
| 101 | ZX-B101E | Screw | M5x8 | 1 |

Headstock Assembly I

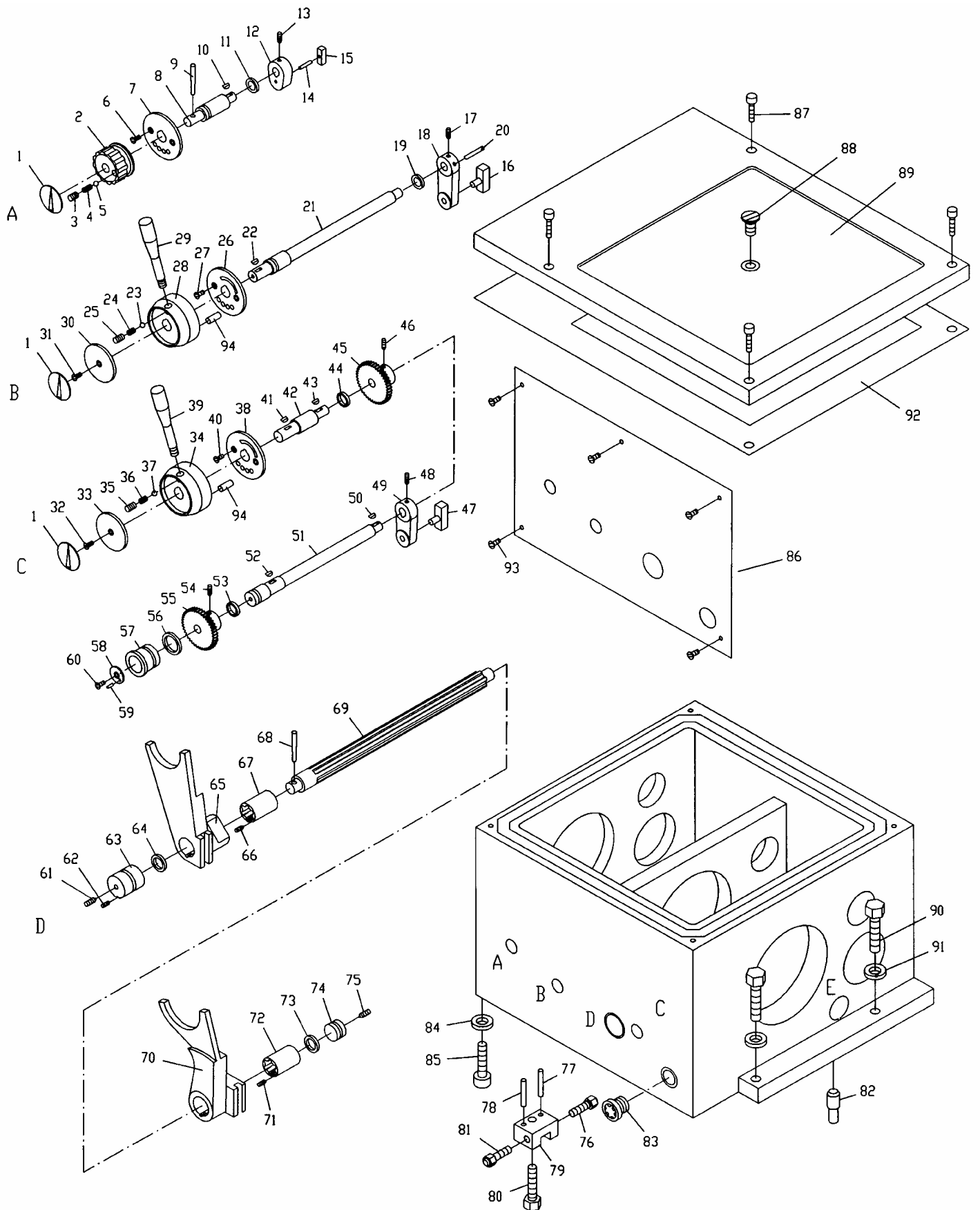

Headstock Assembly I

| Index No. | Part No. | Description | Size | Qty. |
|-----------|------------|------------------------|-----------|------|
| 1 | ZX-02306 | Round Sign Plate | | 3 |
| 2 | ZX-02122 | Positioning Handle | | 1 |
| 3 | ZX-H3 | Flat End Set Screw | M10x12 | 1 |
| 4 | ZX-H4 | Spring | YI-1x8x25 | 1 |
| 5 | ZX-H5 | Steel Ball | 8 | 1 |
| 6 | ZX-H6 | Countersunk Head Screw | M5x12 | 2 |
| 7 | ZX-02743 | Positioning Disc | | 1 |
| 8 | ZX-02738 | Shaft | | 1 |
| 9 | ZX-H9 | Taper Pin | 5x55 | 1 |
| 10 | ZX-H10 | Half Circle Key | 4x16 | 1 |
| 11 | ZX-H11 | Ring Seal | 25x2.4 | 1 |
| 12 | ZX-02116 | Crank | | 1 |
| 13 | TS-1523051 | Set Screw | M6x16 | 1 |
| 14 | ZX-H14 | Pin | 5n6x28 | 1 |
| 15 | ZX-02302 | Poking Block | | 1 |
| 16 | ZX-02738C | Pin Block | | 1 |
| 17 | TS-1523051 | Set Screw | M6x16 | 1 |
| 18 | ZX-02114 | Crank | | 1 |
| 19 | ZX-H11 | Ring Seal | 25x2.4 | 1 |
| 20 | ZX-H20 | Pin | 5x30 | 1 |
| 21 | ZX-02734 | Shaft | | 1 |
| 22 | ZX-H10 | Half Circle Key | 4x16 | 1 |
| 23 | ZX-H5 | Steel Ball | 8 | 1 |
| 24 | ZX-H4 | Spring | YI-1x8x25 | 1 |
| 25 | ZX-H3 | Flat End Set Screw | M10x12 | 1 |
| 26 | ZX-02733 | Left Positioning Disc | | 1 |
| 27 | ZX-H6 | Countersunk Head Screw | M5x12 | 2 |
| 28 | ZX-02113 | Left Lever Support | | 1 |
| 29 | ZX-02741 | Handle | | 1 |
| 30 | ZX-02732 | Cover | | 1 |
| 31 | ZX-H6 | Countersunk Head Screw | M5x12 | 1 |
| 32 | ZX-H6 | Countersunk Head Screw | M5x12 | 1 |
| 33 | ZX-02732 | Cover | | 1 |
| 34 | ZX-02119 | Right Lever Support | | 1 |
| 35 | ZX-H3 | Flat End Set Screw | M10x12 | 1 |
| 36 | ZX-H4 | Spring | YI-1x8x25 | 1 |
| 37 | ZX-H5 | Steel Ball | 8 | 1 |
| 38 | ZX-02728 | Right Positioning Disc | | 1 |
| 39 | ZX-02741 | Handle | | 1 |
| 40 | ZX-H6 | Countersunk Head Screw | M5x12 | 2 |
| 41 | ZX-H10 | Half Circle Key | 4x16 | 1 |
| 42 | ZX-02727 | Shaft | | 1 |
| 43 | ZX-H10 | Half Circle Key | 4x16 | 1 |
| 44 | ZX-H11 | Ring Seal | 25x2.4 | 1 |
| 45 | ZX-02730 | Gear | 1.5m36T | 1 |
| 46 | TS-1523051 | Set Screw | M6x16 | 1 |
| 47 | ZX-02738C | Pin Block | | 1 |
| 48 | TS-1523051 | Set Screw | M6x16 | 1 |
| 49 | ZX-02111 | Crank | | 1 |
| 50 | ZX-H10 | Half Circle Key | 4x16 | 1 |
| 51 | ZX-02731/1 | Control Shaft | | 1 |
| 52 | ZX-H 10 | Half Circle Key | 4x16 | 1 |
| 53 | ZX-H11 | Ring Seal | 25x2.4 | 1 |
| 54 | ZX-H54 | Taper End Set Screw | M6x16 | 1 |
| 55 | ZX-02732/2 | Gear | 1.5m36T | 1 |
| 56 | ZX-H56 | Ring Seal | 40x3.1 | 1 |

| Index No. | Part No. | Description | Size | Qty. |
|-----------|-------------|-------------------------------|--------|------|
| 57 | ZX-02110 | Bushing | | 1 |
| 58 | ZX-02729 | Cover | | 1 |
| 59 | ZX-H59 | Pin | 3n6x10 | 1 |
| 60 | ZX-H6 | Countersunk Head Screw | M5x12 | 1 |
| 61 | ZX-H61 | Countersunk Head Screw | M8x12 | 1 |
| 62 | ZX-H62 | Flat End Set Screw | M8x12 | 1 |
| 63 | ZX-02115 | Bearing Support | | 1 |
| 64 | ZX-H64 | Ring Seal | 40x3.1 | 1 |
| 65 | ZX-02115 | Left Fork | | 1 |
| 66 | ZX-H66 | Flat End Set Screw | M6x10 | 1 |
| 67 | ZX-02120A/2 | Bushing | | 1 |
| 68 | ZX-H68 | Taper Pin | 6x35 | 1 |
| 69 | ZX-02736 | Control Shaft | | 1 |
| 70 | ZX-02112 | Right Fork | | 1 |
| 71 | ZX-H66 | Flat End Set Screw | M6x10 | 1 |
| 72 | ZX-02120A/2 | Bushing | | 1 |
| 73 | ZX-H73 | Ring Seal | 30x3.1 | 1 |
| 74 | ZX-02735 | Blocking Piece | | 1 |
| 75 | ZX-H61 | Countersunk Head Screw | M8x12 | 1 |
| 76 | ZX-02744 | Adjusting Screw | | 1 |
| 77 | ZX-H77 | Taper Pin | 8x40 | 1 |
| 78 | ZX-H77 | Taper Pin | 8x40 | 1 |
| 79 | ZX-92124 | Adjusting Block | | 1 |
| 80 | ZX-H80 | Hex Cap Bolt | M12x50 | 1 |
| 81 | ZX-02744 | Adjusting Screw | | 1 |
| 82 | ZX-02736C | Positioning Pin | | 1 |
| 83 | ZX-H83 | Oil Sight Glass | | 1 |
| 84 | ZX-H84 | Washer | A16 | 2 |
| 85 | ZX-H85 | Hex Socket Cap Screw | M16x50 | 2 |
| 86 | ZX-02301A | Label (for 1440ZX) | | 1 |
| | ZX-02301B | Label (for 1460ZX) | | 1 |
| | ZX-02301C | Label (for 1640ZX) | | 1 |
| | ZX-02301D | Label (for 1660ZX) | | 1 |
| | ZX-02301E | Label (for 1840ZX) | | 1 |
| | ZX-02301F | Label (for 1860ZX) | | 1 |
| | ZX-02301G | Label (for 1880ZX) | | 1 |
| 87 | TS-1504071 | Hex Socket Cap Screw | M8x35 | 4 |
| 88 | ZX-H88 | Countersunk Head Screw | M16x25 | 1 |
| 89 | ZX-02117 | Top Cover | | 1 |
| 90 | ZX-H90 | Hex Cap Bolt | | 2 |
| 91 | ZX-H91 | Washer | A16 | 2 |
| 92 | ZX-02505 | Paper Gasket | | 1 |
| 93 | ZX-H93 | Cross Recessed Pan Head Screw | M3x6 | 7 |
| 94 | ZX-H94N | Pin | 4n6x15 | 2 |

Headstock Assembly II

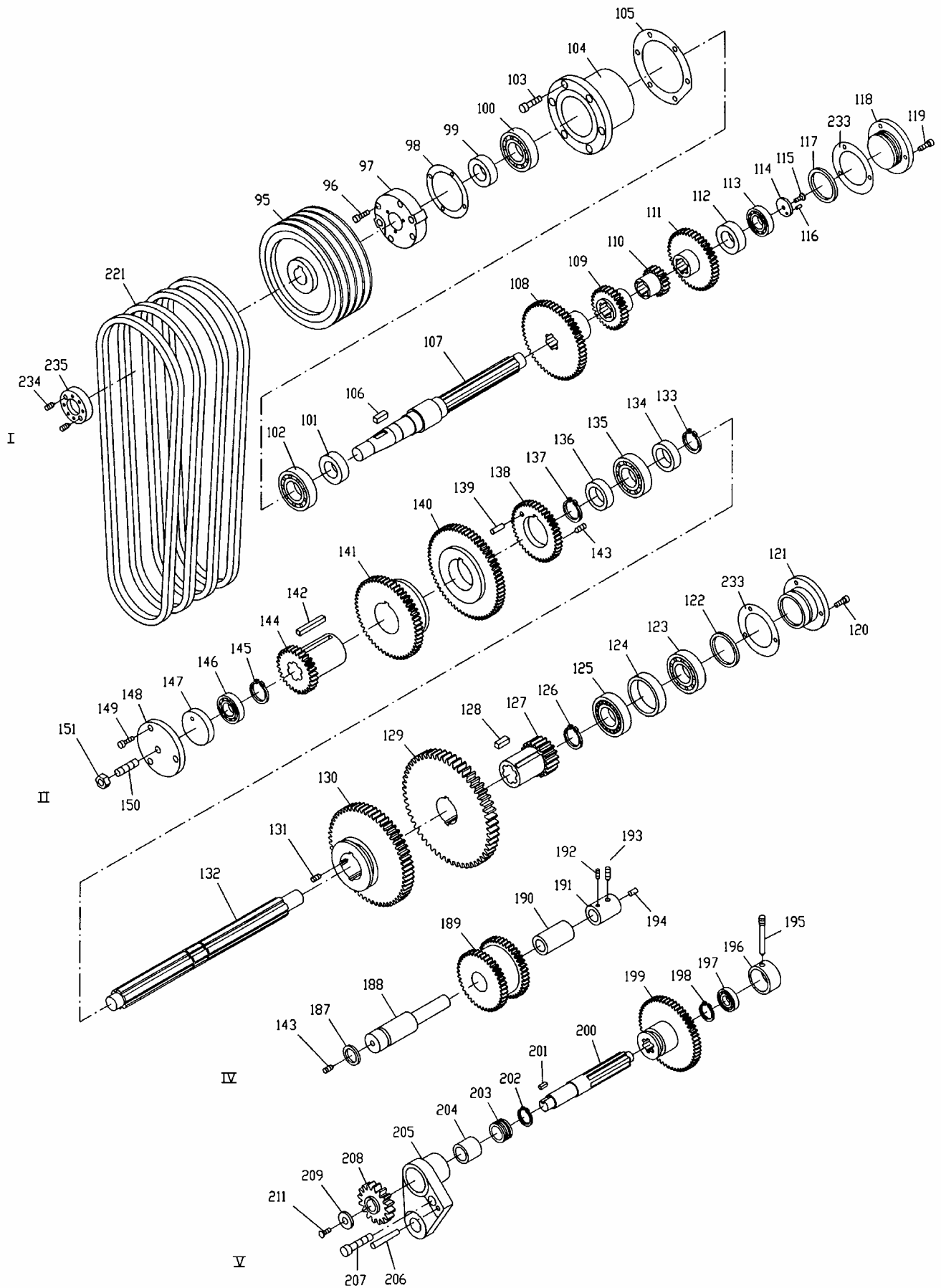

Headstock Assembly II

| Index No. | Part No. | Description | Size | Qty. |
|-----------|--------------|---------------------------|----------|------|
| 95 | ZX-02107 | Pulley | | 1 |
| 96 | TS-1514041 | Hex Socket Cap Screw | M6x25 | 4 |
| 97 | ZX-02106 | Bearing Cover | | 1 |
| 98 | ZX-02506 | Gasket | | 1 |
| 99 | ZX-H99 | Ring Seal | 32x52 | 1 |
| 100 | BB-6207 | Ball Bearing | 35x72x17 | 1 |
| 101 | BB-6207 | Ball Bearing | 35x72x17 | 1 |
| 102 | ZX-H102 | Sleeve | 30x10 | 1 |
| 103 | TS-1515031 | Hex Socket Cap Screw | M8x25 | 6 |
| 104 | ZX-02105 | Bearing Support | | 1 |
| 105 | ZX-02502 | Gasket | | 1 |
| 106 | ZX-H106 | Flat Key | 10x8x35 | 1 |
| 107 | ZX-02709 | Shaft | | 1 |
| 108 | ZX-02754X | Gear (for 14" models) | 2.5m52T | 1 |
| | ZX-02754X/6P | Gear (for 16"/18" models) | 2.5m61T | 1 |
| 109 | ZX-02753X | Gear (for 14" models) | 2.5m28T | 1 |
| | ZX-02753X/6P | Gear (for 16"/18" models) | 2.5m32T | 1 |
| 110 | ZX-02752X | Gear | 2.5m18T | 1 |
| 111 | ZX-02751X | Gear (for 14" models) | 2.5m41T | 1 |
| | ZX-02751X/6P | Gear (for 16"/18" models) | 2.5m47T | 1 |
| 112 | ZX-H112 | Sleeve | | 1 |
| 113 | BB6305/P6 | Ball Bearing | 25x62x17 | 1 |
| 114 | ZX-H114 | Shaft End Lock Ring | 32 | 1 |
| 115 | ZX-H115 | Countersunk Head Screw | M6x20 | 1 |
| 116 | ZX-H59 | Pin | 3n6x10 | 1 |
| 117 | ZX-H117 | Ring Seal | 60x3.1 | 1 |
| 118 | ZX-02104 | Blocking Flange | | 1 |
| 119 | TS-1514021 | Hex Socket Cap Screw | M6x15 | 3 |
| 120 | TS-1514021 | Hex Socket Cap Screw | M6x15 | 3 |
| 121 | ZX-02103 | Blocking Flange | | 1 |
| 122 | ZX-H117 | Ring Seal | 60x3.1 | 1 |
| 123 | BB-6305 | Ball Bearing | 25x62x17 | 1 |
| 124 | ZX-H124 | Sleeve | 62x6 | 1 |
| 125 | BB-6305 | Ball Bearing | 25x62x17 | 1 |
| 126 | ZX-H126 | Circle Clip For Shaft | 35 | 1 |
| 127 | ZX-02705 | Gear | 3m19T | 1 |
| 128 | ZX-H128 | Flat Key | 8x7x50 | 2 |
| 129 | ZX-02706 | Gear | 3m67T | 1 |
| 130 | ZX-02707 | Gear | 3m59T | 1 |
| 131 | ZX-H62 | Flat End Set Screw | M8x12 | 1 |
| 132 | ZX-02708 | Shaft | | 1 |
| 133 | ZX-H133 | C-Clip | 35 | 1 |
| 134 | ZX-H134 | Sleeve | 35x8 | 1 |
| 135 | BB-6007 | Ball Bearing | 35x62x14 | 1 |
| 136 | ZX-H136 | Sleeve | 35x8 | 1 |
| 137 | ZX-H133 | C-Clip | 35 | 1 |
| 138 | ZX-02756 | Gear (for 14" models) | 2.5m42T | 1 |
| | ZX-02756/6P | Gear (for 16"/18" models) | 2.5m36T | 1 |
| 139 | ZX-H139 | Pin | 8n6x25 | 1 |
| 140 | ZX-02757 | Gear (for 14" models) | 2.5m65T | 1 |
| | ZX-02757/6P | Gear (for 16"/18" models) | 2.5m65T | 1 |
| 141 | ZX-02758 | Gear (for 14" models) | 2.5m55T | 1 |
| | ZX-02758/6P | Gear (for 16"/18" models) | 2.5m51T | 1 |
| 142 | ZX-H142 | Flat Key | 10x6x60 | 2 |
| 143 | ZX-H143 | Flat Head Set Screw | M8x12 | 2 |
| 144 | ZX-02755X | Gear (for 14" models) | 2.5m31T | 1 |

| Index No. | Part No. | Description | Size | Qty. |
|-----------|---------------|--|----------|------|
| | ZX-02755X/6P | Gear (for 16"/18" models) | 2.5m22T | 1 |
| 145 | ZX-H133 | C-Clip | 35 | 1 |
| 146 | BB-6305 | Ball Bearing | 25x62x17 | 1 |
| 147 | ZX-H147 | Pushing Disc | 62 | 1 |
| 148 | ZX-02109C | Cover | | 1 |
| 149 | TS-1514021 | Hex Socket Cap Screw | M6x15 | 3 |
| 150 | ZX-H150 | Set Screw | M12x65 | 1 |
| 151 | ZX-H151 | Hex Nut | M12 | 1 |
| 187 | ZX-H187 | Ring Seal | 35x3.1 | 1 |
| 188 | ZX-02714 | Shaft | | 1 |
| 189 | ZX-02716 | Double Gear | 2m48T | 1 |
| 190 | ZX-02303 | Copper Sleeve | | 1 |
| 191 | ZX-02734C | Positioning Sleeve | | 1 |
| 192 | TS-1523031 | Set Screw | M6x10 | 1 |
| 193 | TS-1524041 | Set Screw | M8x15 | 1 |
| 194 | ZX-02733C | Blocking Piece | | 1 |
| 195 | ZX-02718 | Taper End Set Screw | | 1 |
| 196 | ZX-02114C | Sleeve | | 1 |
| 197 | BB-6203 | Ball Bearing | 17x40x12 | 1 |
| 198 | ZX-H198 | C-Clip | 28 | 1 |
| 199 | ZX-02717 | Gear | 2m65T | 1 |
| 200 | ZX-02715 | Shaft | | 1 |
| 201 | ZX-H201 | Flat Key | 5x5x1 | 1 |
| 202 | ZX-H198 | C-Clip | 28 | 1 |
| 203 | ZX-02722C | Sleeve | | 1 |
| 204 | ZX-02301 | Oil Bushing | | 1 |
| 205 | ZX-08106A | Bracket (for Shaft V, Vb) (for 14"/16" models) | | 1 |
| | ZX-08106B | Bracket (for Shaft V, Vb) (for 18" models) | | 1 |
| 206 | ZX-H77 | Taper Pin | 8x40 | 1 |
| 207 | TS-1516021 | Hex Socket Cap Screw | M10x25 | 1 |
| 208 | TNMP08706A(N) | Gear (for 14"/16" models) | 3.5m16T | 1 |
| | TNMP08706B(N) | Gear (for 18" models) | 4m16T | 1 |
| 209 | ZX-02724C | Washer | | 1 |
| 210 | ZX-H59 | Pin | 3n6x10 | 1 |
| 211 | ZX-H211 | Countersunk Head Screw | M5x16 | 1 |
| 221 | VB-A78 | V-Belt (for 14" models) | A-78 | 4 |
| | VB-A79 | V-Belt (for 16" models) | A-79 | 4 |
| | VB-A81 | V-Belt (for 18" models) | A-81 | 4 |
| 233 | ZX-02506 | Paper Gasket | | 2 |
| 234 | ZX-H234 | Set Screw | M8x6 | 2 |
| 235 | ZX-02743N | Clamping Round Nut | | 1 |
| 236 | ZX-H236 | Pin | 8x30 | 2 |

Headstock Assembly III

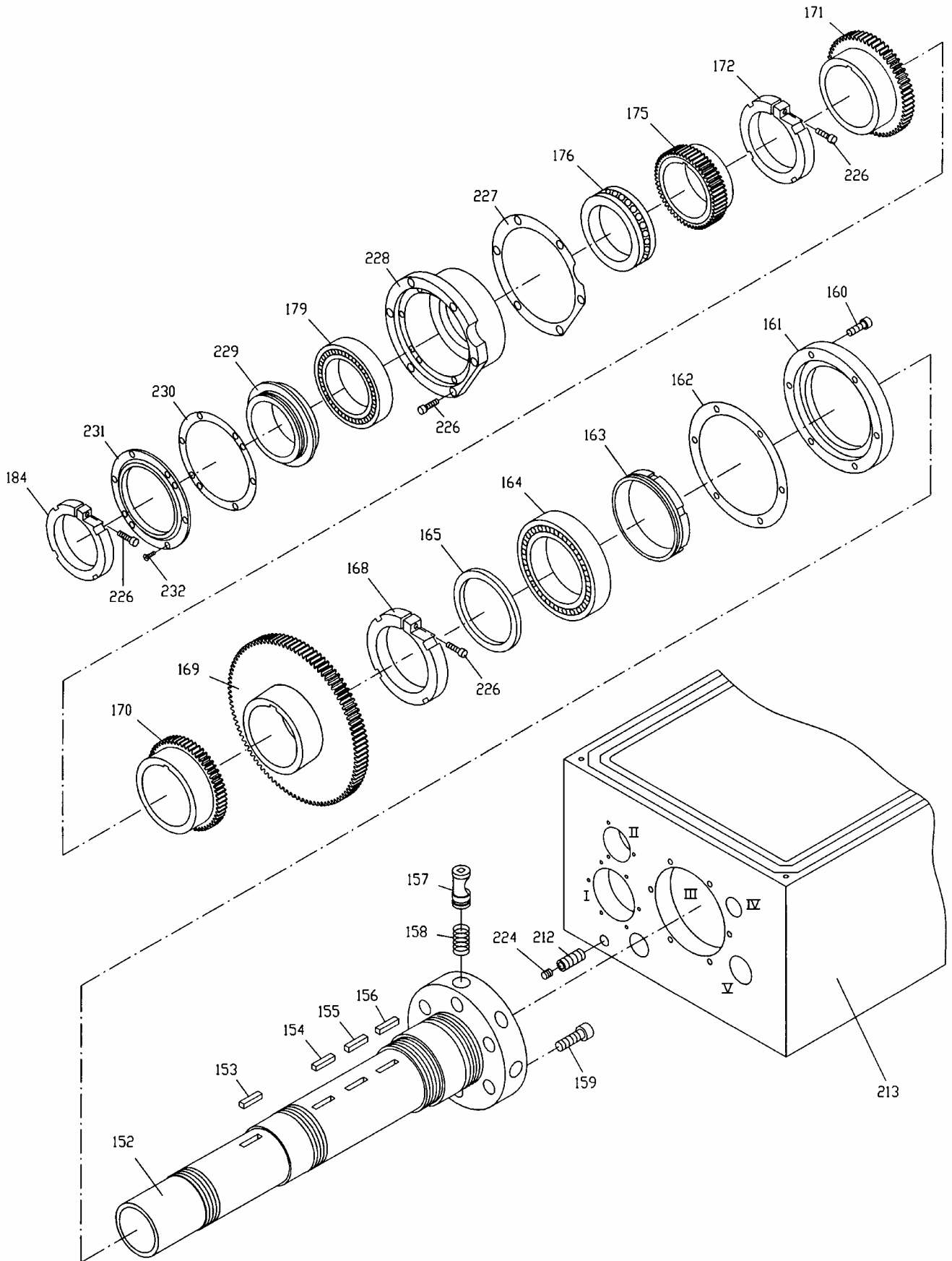

Headstock Assembly III

| Index No. | Part No. | Description | Size | Qty. |
|-----------|--------------|--|------------|------|
| 152 | ZX-02704 | Spindle | | 1 |
| 153 | ZX-H153 | Flat Key | 10x8x40 | 1 |
| 154 | ZX-H154 | Flat Key | 10x8x50 | 1 |
| 155 | ZX-H155 | Flat Key | 12x8x50 | 1 |
| 156 | ZX-H156 | Flat Key | 14x9x50 | 1 |
| 157 | ZX-02701 | Cam Lock | | 6 |
| 158 | ZX-H158 | Spring | 1x8x25 | 6 |
| 159 | ZX-02703 | Cam Positioning Screw | | 6 |
| 160 | TS-1516031 | Hex Socket Cap Screw | M10x28 | 6 |
| 161 | ZX-02102 | Bearing Front Cover | | 1 |
| 162 | ZX-02501 | Gasket | | 1 |
| 163 | ZX-02702 | Oil Splashing Ring | | 1 |
| 164 | NN3024/P5 | Taper Roller Bearing | 120x180x46 | 1 |
| 165 | ZX-02726 | Lining | | 1 |
| 168 | ZX-02725A | Round Nut w/Screw | | 1 |
| 169 | ZX-02723 | Gear | 3m98T | 1 |
| 170 | ZX-02722 | Gear | 3m50T | 1 |
| 171 | ZX-02721 | Gear | 3m58T | 1 |
| 172 | ZX-02720A | Round Nut w/Screw | | 1 |
| 175 | ZX-02710 | Gear | 2m65T | 1 |
| 176 | 51120/P5 | Thrust Bearing | 100x135x25 | 1 |
| 179 | BB-7020AC/P5 | Angular Bearing | 100x150x24 | 1 |
| 184 | ZX-02713A | Round Nut w/Screw | | 1 |
| 212 | ZX-H212 | Drain Plug (14" models, Serial #001204ZX258 and lower) | | 1 |
| | | Drain Plug (16" models, Serial #010312ZX293 and lower, also includes Serial #010319ZX298 & 299) | | 1 |
| | | Drain Plug (18" models, Serial #010416ZX313 and lower) | | 1 |
| 212 | ZX-H212A | Drain plug (14" models, Serial #010105ZX263 and higher) | | 1 |
| | | Drain plug (16" models, Serial #010319ZX294 and higher, except for Serial #010319ZX298 & 299) | | 1 |
| | | Drain plug (18" models, Serial #010514ZX323 and higher) | | 1 |
| 213 | ZX-02101A | Headstock Casting (14" models, Serial #001204ZX258 and lower) | | 1 |
| | ZX-02101AN | Headstock Casting (14" models, Serial #010105ZX263 and higher) | | 1 |
| | ZX-02101B | Headstock Casting (16" models, Serial #010312ZX293 and lower, also includes Serial #010319ZX298 & 299) | | 1 |
| | ZX-02101BN | Headstock Casting (16" models, Serial #010319ZX294 and higher, except for Serial #010319ZX298 & 299) | | 1 |
| | ZX-02101C | Headstock Casting (18" models, Serial #010416ZX313 and lower) | | 1 |
| | ZX-02101CN | Headstock Casting (18" models, Serial #010514ZX323 and higher) | | 1 |
| 224 | ZX-G38-3A | Screw | | 1 |
| 226 | ZX-H226 | Hex Socket Cap Screw | M8x28 | 9 |
| 227 | ZX-02502F | Gasket | | 1 |
| 228 | ZX-02108F | Bearing Support | | 1 |
| 229 | ZX-02711F | Sleeve | | 1 |
| 230 | ZX-02510F | Gasket | | 1 |
| 231 | ZX-02761F | Bearing Back Cover | | 1 |
| 232 | ZX-H232 | Screw | M5x10 | 6 |

Headstock Assembly IV

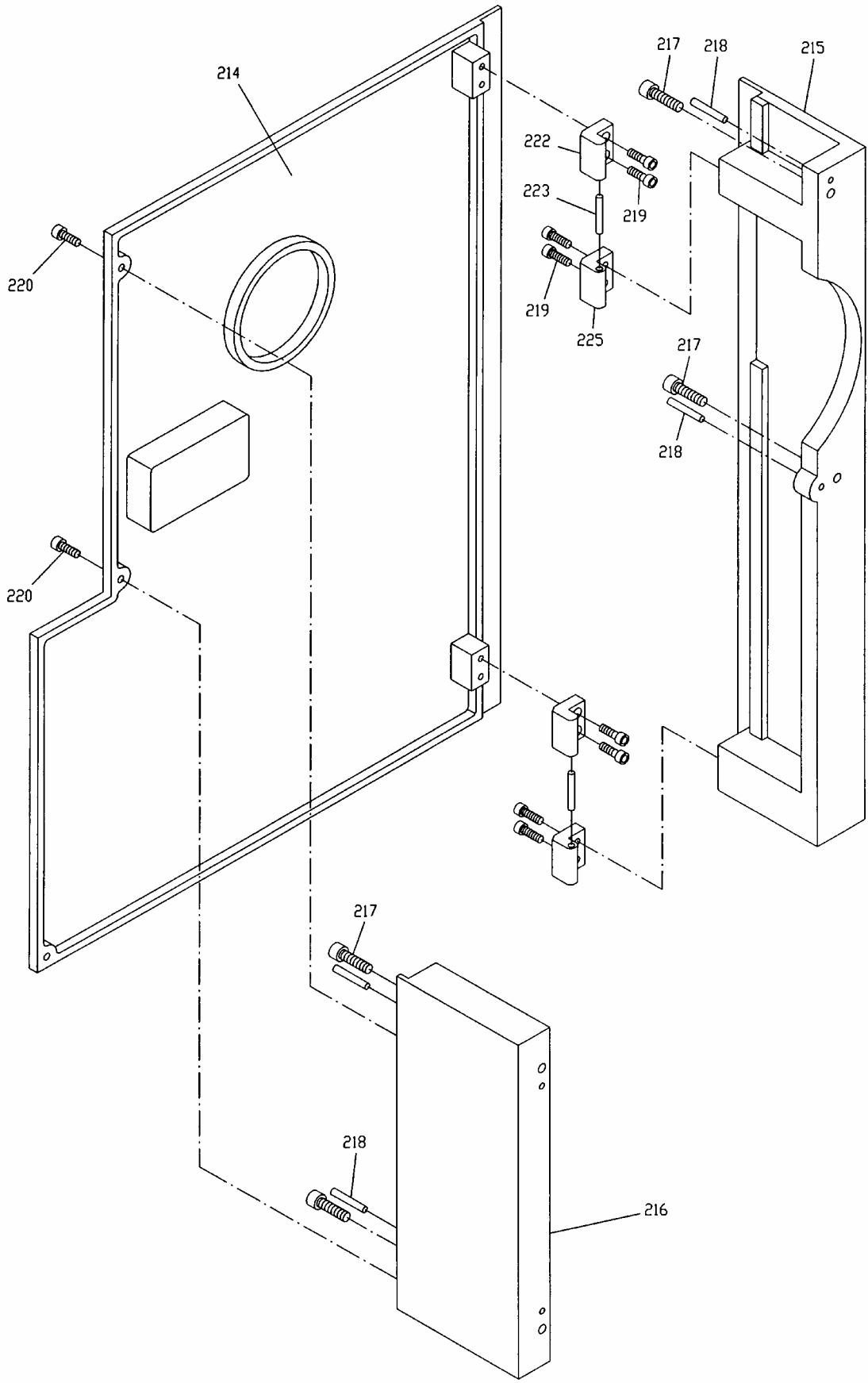

Headstock Assembly IV

| Index No. | Part No. | Description | Size | Qty. |
|-----------|------------|-----------------------------------|--------|------|
| 214 | ZX-08302A | Back Cover (for 14" models) | | 1 |
| | ZX-08302B | Back Cover (for 16" models) | | 1 |
| | ZX-08302C | Back Cover (for 18" models) | | 1 |
| 215 | ZX-08114A | Rear Side plate (for 14" models) | | 1 |
| | ZX-08114B | Rear Side plate (for 16" models) | | 1 |
| | ZX-08114C | Rear Side plate (for 18" models) | | 1 |
| 216 | ZX-08113A | Front Side plate (for 14" models) | | 1 |
| | ZX-08113B | Front Side plate (for 16" models) | | 1 |
| | ZX-08113C | Front Side plate (for 18" models) | | 1 |
| 217 | TS-1515031 | Hex Socket Cap Screw | M8x25 | 4 |
| 218 | ZX-H218 | Taper Pin | 6x25 | 4 |
| 219 | TS-1514031 | Hex Socket Cap Screw | M6x20 | 8 |
| 220 | TS-1514021 | Hex Socket Cap Screw | M6x15 | 3 |
| 222 | ZX-08712 | Upper Hinge | | 2 |
| 223 | ZX-H223 | Pin | 6n6x40 | 2 |
| 225 | ZX-08711 | Lower Hinge | | 2 |

Change Gear Box Assembly I

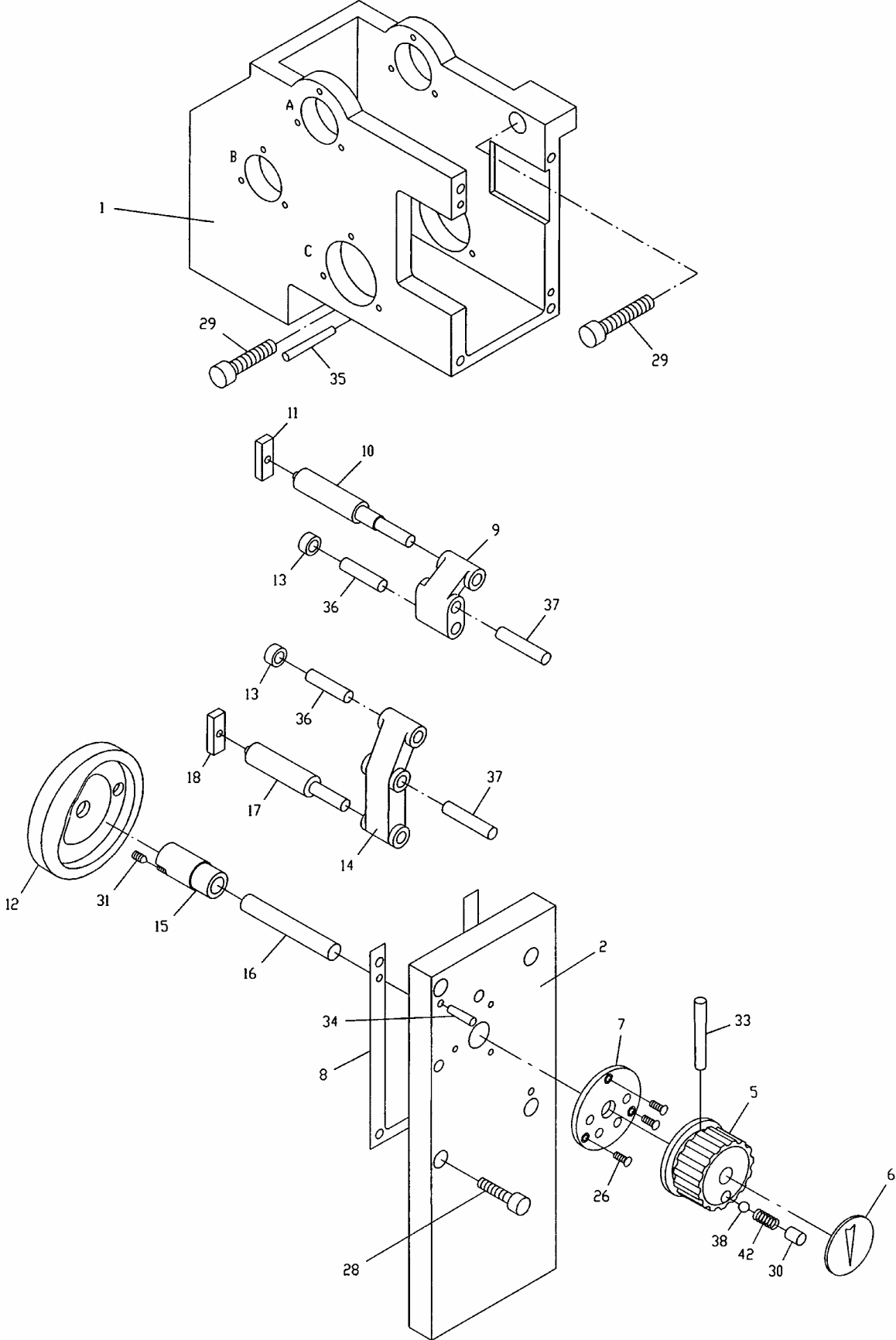

Change Gear Box Assembly I

| Index No. | Part No. | Description | Size | Qty. |
|-----------|------------|-------------------------|---------|------|
| 1 | ZX-08101 | Change Gear Box Casting | | 1 |
| 2 | ZX-08108 | Front Cover | | 1 |
| 5 | ZX-05104C | Hand Wheel | | 1 |
| 6 | ZX-05301C | Sign Plate | | 1 |
| 7 | ZX-08708 | Positioning Disc | | 1 |
| 8 | ZX-08505 | Gasket | | 1 |
| 9 | ZX-08111 | Crank | | 1 |
| 10 | ZX-08705 | Connecting Rod | | 1 |
| 11 | ZX-08304 | Sliding Block | | 1 |
| 12 | ZX-05103C | Cam | | 1 |
| 13 | ZX-05702C | Roller | | 2 |
| 14 | ZX-08109 | Crank | | 1 |
| 15 | ZX-08110 | Bushing | | 1 |
| 16 | ZX-08704 | Rotating Shaft | | 1 |
| 17 | ZX-08703 | Connecting Rod | | 1 |
| 18 | ZX-08304 | Sliding Block | | 1 |
| 26 | ZX-C26 | Cross Head Screw | M4x12 | 3 |
| 28 | TS-1515031 | Hex Socket Cap Screw | M8x25 | 4 |
| 29 | TS-1516051 | Hex Socket Cap Screw | M10x40 | 2 |
| 30 | TS-1525021 | Set Screw | M10x12 | 1 |
| 31 | ZX-C31 | Flat Head Set Screw | M6x8 | 1 |
| 33 | ZX-C33 | Taper Pin | 4x45 | 1 |
| 34 | ZX-C34 | Taper Pin | 6x30 | 2 |
| 35 | ZX-C35 | Taper Pin | 6x50 | 1 |
| 36 | ZX-C36 | Pin | 10m6x40 | 2 |
| 37 | ZX-C37 | Pin | 10m6x50 | 2 |
| 38 | ZX-H5 | Steel Ball | 8 | 1 |
| 42 | ZX-C42 | Spring | 1x8x30 | 1 |

Change Gear Box Assembly II

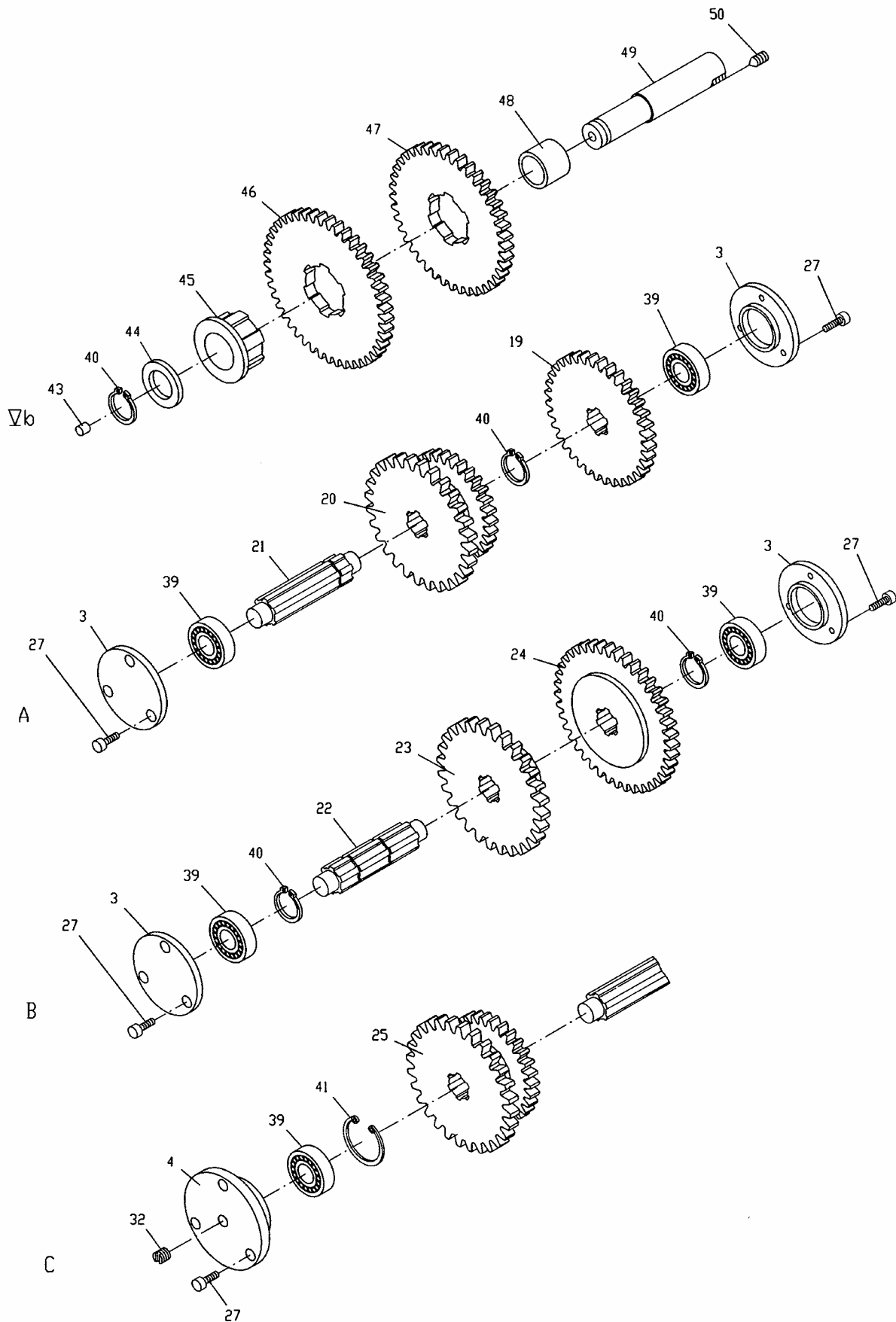

Change Gear Box Assembly II

| Index No. | Part No. | Description | Size | Qty. |
|-----------|------------|---------------------------|----------------|------|
| 3 | ZX-08104 | End Cover | | 4 |
| 4 | ZX-08103 | Bearing Support | | 1 |
| 19 | ZX-08107 | Gear | 3m36T | 1 |
| 20 | ZX-08105 | Double Gear | 3.75m28T/3m30T | 1 |
| 21 | ZX-08702 | Shaft | | 1 |
| 22 | ZX-08701 | Shaft | | 1 |
| 23 | ZX-08710 | Gear | 3.75m27T | 1 |
| 24 | ZX-08709 | Gear | 3m41T | 1 |
| 25 | ZX-08102 | Double Gear | 3.75m30T/3m29T | 1 |
| 27 | ZX-C27 | Slotted Cheese Head Screw | M5x12 | 15 |
| 32 | ZX-C32 | Flat Head Set Screw | M10x12 | 1 |
| 39 | BB-6203 | Ball Bearing | 17x40x12 | 5 |
| 40 | ZX-C40 | C-Clip | 25 | 4 |
| 41 | ZX-C41 | C-Clip | 40 | 1 |
| 43 | ZX-C43 | Oil Cup | 8 | 1 |
| 44 | TNMP08108 | Washer | | 1 |
| 45 | TNMP08102 | Splinted Sleeve | | 1 |
| 46 | TNMP08504 | Gear | 3m41T | 1 |
| 47 | TNMP08501A | Gear (for 14"/16" models) | 3.5m36T | 1 |
| | TNMP08501B | Gear (for 18" models) | 4m36T | 1 |
| 48 | ZX-05502C | Oil Bushing | | 1 |
| 49 | ZX-08707 | Shaft Vb | | 1 |
| 50 | ZX-C50 | Flat Head Set Screw | M8x10 | 1 |

Quick Change Gear Box I

| Index No. | Part No. | Description | Size | Qty. |
|-----------|------------|------------------------|--------|------|
| 1 | ZX-05153A | Upper Cover | | 1 |
| 2 | TS-1514051 | Hex Socket Cap Screw | M6x30 | 2 |
| 6 | TS-1515011 | Hex Socket Cap Screw | M8x16 | 10 |
| 7 | ZX-05109 | Rear Cover | | 1 |
| 8 | ZX-05502 | Gasket | | 1 |
| 9 | ZX-Q09 | Countersunk Head Screw | M10x18 | 1 |
| 10 | ZX-05101 | Feedbox Casting | | 1 |
| 11 | ZX-05501 | Gasket | | 1 |
| 12 | ZX-05108 | Flange | | 1 |
| 13 | TS-1515011 | Hex Socket Cap Screw | M8x16 | 6 |
| 14 | ZX-05151 | Extending Plate | | 1 |
| 15 | TS-1503131 | Hex Socket Cap Screw | M6x60 | 4 |
| 19 | ZX-Q19 | Hex Cap Bolt | M10x1 | 1 |
| 20 | TS-1491061 | Hex Cap Bolt | M10x40 | 2 |
| 21 | ZX-H68 | Taper Pin | 6x35 | 2 |
| 22 | ZX-05738 | Control Shaft | | 1 |
| 23 | ZX-05739 | Sliding Key | | 3 |
| 24 | ZX-05128 | Sliding Sleeve | | 3 |
| 25 | ZX-Q25 | Flat Head Set Screw | M5x8 | 4 |
| 26 | ZX-05125 | Right Fork | | 1 |
| 27 | ZX-05126 | Middle Fork | | 1 |
| 28 | ZX-05127 | Left Fork | | 1 |
| 29 | ZX-Q29 | Ring Seal | 32x3.1 | 1 |
| 30 | ZX-Q30 | Taper Pin | 4x25 | 2 |
| 31 | ZX-05129 | Cover | | 1 |
| 32 | ZX-Q32 | Pin | 5n6x15 | 1 |
| 33 | ZX-Q33 | Cheese Head Screw | M5x16 | 3 |
| 34 | ZX-05122 | Cam | | 1 |
| 35 | ZX-05728 | Rolling Sleeve | | 5 |
| 36 | ZX-05729 | Poking Key | | 3 |
| 37 | ZX-05123 | Crank | | 1 |
| 38 | ZX-Q38 | Pin | 8n6x32 | 5 |
| 39 | ZX-Q39 | Pin | 6n6x20 | 5 |
| 40 | ZX-05124 | Crank | | 1 |
| 41 | ZX-05111 | Sleeve | | 1 |
| 42 | ZX-05726 | Lever Shaft | | 1 |
| 43 | ZX-Q43 | Taper Pin | 4x32 | 2 |
| 44 | ZX-Q44 | Taper Pin | 4x65 | 1 |
| 45 | ZX-05121 | Crank | | 1 |
| 46 | ZX-05118 | Cam | | 1 |
| 47 | ZX-05120 | Crank | | 1 |
| 48 | ZX-05116 | Fork | | 1 |
| 49 | ZX-Q49 | Pin | 8n6x18 | 2 |
| 50 | ZX-05117 | Sleeve | | 1 |
| 51 | ZX-05737 | Lever Shaft | | 1 |
| 52 | ZX-C33 | Taper Pin | 4x45 | 2 |
| 53 | ZX-05115 | Fork | | 1 |
| 54 | ZX-05119 | Crank | | 1 |
| 55 | ZX-05735 | Pin | | 1 |
| 56 | ZX-05112 | Fork | | 1 |
| 57 | ZX-05113 | Crank | | 1 |
| 58 | ZX-05730 | Small Shaft | | 1 |
| 59 | ZX-05731 | Big Gear | 1m44T | 1 |
| 60 | ZX-05732 | Small Gear | 1m22T | 1 |

| Index No. | Part No. | Description | Size | Qty. |
|------------------|-----------------|------------------------|-------------|-------------|
| 61 | ZX-05114 | Sleeve | | 1 |
| 62 | ZX-05734 | Lever Shaft | | 1 |
| 63 | ZX-05503 | Gasket | | 1 |
| 64 | ZX-05110 | Front Cover | | 1 |
| 65 | TS-1516011 | Hex Socket Cap Screw | M10x20 | 5 |
| 66 | ZX-Q66 | Taper Pin | 5x35 | 6 |
| 67 | ZX-05303A | Sign Plate | | 1 |
| 68 | ZX-Q68 | Cross Head Screw | M3x6 | 7 |
| 69 | ZX-Q69 | Oil Sight Glass | 20 | 1 |
| 70 | ZX-05727 | Positioning Disc | | 1 |
| 71 | ZX-Q71 | Countersunk Head Screw | M4x12 | 9 |
| 72 | ZX-05740 | Lever | | 1 |
| 73 | ZX-05130A | Lever Support | | 1 |
| 74 | ZX-05301 | Sign Disc | | 3 |
| 75 | ZX-H5 | Steel Ball | 8 | 3 |
| 76 | ZX-Q76 | Compression Spring | YZ-1x8x25 | 3 |
| 77 | ZX-H3 | Flat End Set Screw | M10x12 | 3 |
| 78 | ZX-05736 | Positioning Disc | | 1 |
| 79 | ZX-05140 | Hand Wheel | | 2 |
| 80 | ZX-05733 | Positioning Disc | | 1 |

Quick Change Gear Box II

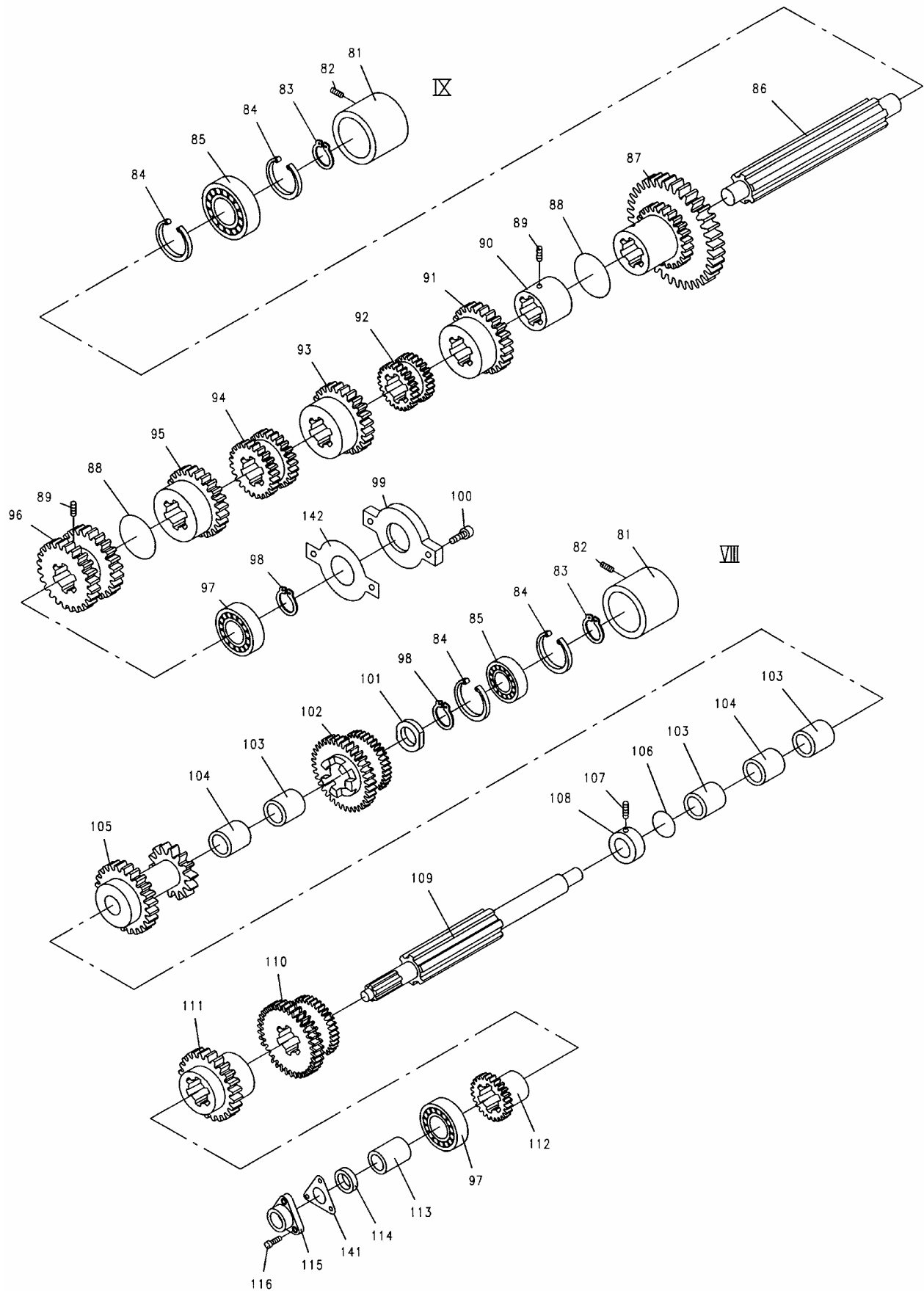

Quick Change Gear Box II

| Index No. | Part No. | Description | Size | Qty. |
|-----------|------------|--------------------------------|-------------------|------|
| 81 | ZX-05104 | Middle Bearing Support | | 2 |
| 82 | ZX-Q82 | Taper End Set Screw | M10x16 | 2 |
| 83 | ZX-B23 | C-Clip | 20 | 3 |
| 84 | ZX-Q84 | C-Clip | 42 | 5 |
| 85 | BB-6004 | Single Row Radial Ball Bearing | 20x42x12 | 5 |
| 86 | ZX-05721 | Shaft | | 1 |
| 87 | ZX-05722 | Double Gear | 2m26T/2m52T | 1 |
| 88 | ZX-Q88 | Iron Wire | 1x190 | 2 |
| 89 | TS-1524051 | Set Screw | M8x20 | 2 |
| 90 | ZX-05720 | Positioning Sleeve | | 1 |
| 91 | ZX-05719 | Gear | 2.25m28T | 1 |
| 92 | ZX-05718 | Double Gear | 2m26T/2m28T | 1 |
| 93 | ZX-05717 | Gear | 3.5m20T | 1 |
| 94 | ZX-05716 | Double Gear | 3.5m18T/3.5m19T | 1 |
| 95 | ZX-05715 | Gear | 3.25m22T | 1 |
| 96 | ZX-05714 | Double Gear | 3.25m24T/3.25m23T | 1 |
| 97 | BB-6205 | Single Row Radial Ball Bearing | 25x52x15 | 2 |
| 98 | ZX-C40 | C-Clip | 25 | 3 |
| 99 | ZX-05125 | Shaft End Cover | | 1 |
| 100 | TS-1515011 | Hex Socket Cap Screw | M8x18 | 2 |
| 101 | ZX-05704 | Spacer | | 1 |
| 102 | ZX-05705 | Double Gear | 2m52T/2m26T | 1 |
| 103 | ZX-05502C | Oil Bushing | | 3 |
| 104 | ZX-05105 | Sleeve | | 2 |
| 105 | ZX-05707 | Double Gear | 2m39T/2m26T | 1 |
| 106 | ZX-Q106 | Iron Wire | 1x160 | 3 |
| 107 | TS-1524031 | Set Screw | M8x12 | 3 |
| 108 | ZX-05714C | Fixed Bushing | | 1 |
| 109 | ZX-05710 | Shaft | | 1 |
| 110 | ZX-05709 | Double Gear | 2m48T/2.25m42T | 1 |
| 111 | ZX-05711 | Sliding Gear | 3.5m24T | 1 |
| 112 | ZX-05712 | Sliding Gear | 3.25m24T | 1 |
| 113 | ZX-05713 | Sleeve | | 1 |
| 114 | ZX-G51-1 | Spacer | 32 | 1 |
| 115 | ZX-05106 | Bearing Support | | 1 |
| 116 | TS-1515031 | Hex Socket Cap Screw | M8x25 | 3 |
| 141 | ZX-05504 | Gasket | | 1 |
| 142 | ZX-05505 | Gasket | | 1 |

Quick Change Gear Box III

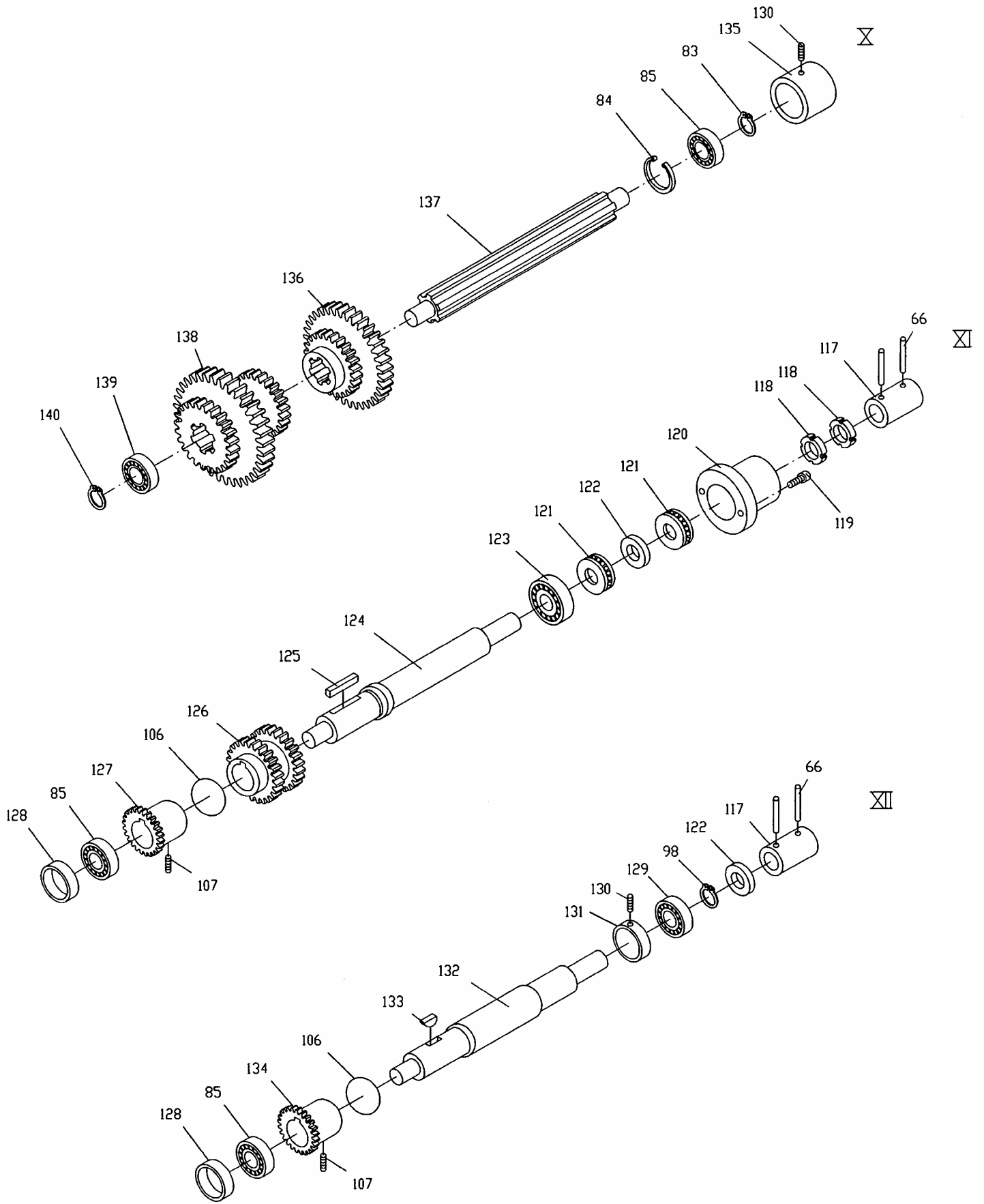

Quick Change Gear Box III

| Index No. | Part No. | Description | Size | Qty. |
|-----------|------------|--------------------------------|-------------------|------|
| 66 | ZX-Q66 | Taper Pin | 5x35 | 6 |
| 83 | ZX-Q83 | C-Clip | 20 | 3 |
| 84 | ZX-Q84 | C-Clip | 42 | 5 |
| 85 | BB104 | Single Row Radial Ball Bearing | 20x42x12 | 5 |
| 98 | ZX-Q98 | C-Clip | 25 | 3 |
| 106 | ZX-Q106 | Iron Wire | 1x160 | 3 |
| 107 | TS-1524031 | Set Screw | M8x12 | 3 |
| 117 | ZX-05113C | Shaft Coupling | | 2 |
| 118 | ZX-Q118 | Round Nut | M24x1.5 | 2 |
| 119 | TS-1503021 | Hex Socket Cap Screw | M6x10 | 2 |
| 120 | ZX-05114 | Cover | | 1 |
| 121 | BB-51105 | Thrust Bearing | 25x42x11 | 2 |
| 122 | ZX-Q122 | Spacer | 25 | 2 |
| 123 | BB-6305 | Ball Bearing | 25x62x17 | 1 |
| 124 | ZX-05725 | Shaft | | 1 |
| 125 | ZX-Q125 | Key | 8x7x50 | 1 |
| 126 | ZX-05724 | Double Gear | 2.25m35T/2.25m36T | 1 |
| 127 | ZX-05723 | Gear | 2.5m36T | 1 |
| 128 | ZX-05107 | Sleeve | | 2 |
| 129 | BB-6005 | Ball Bearing | 25x47x12 | 1 |
| 130 | TS-1525021 | Set Screw | M10x12 | 2 |
| 131 | ZX-05103 | Bearing Support | | 1 |
| 132 | ZX-05701 | Shaft | | 1 |
| 133 | ZX-Q133 | Half Circle Key | 6x22 | 1 |
| 134 | ZX-05703 | Gear | 2.5m36T | 1 |
| 135 | ZX-05102 | Bearing Support | | 1 |
| 136 | ZX-05702 | Double Gear | 2.5m24T/2.25m35T | 1 |
| 137 | ZX-05708 | Shaft | | 1 |
| 138 | ZX-05706 | Triple Gear | 2m39T/2m52T/2m26T | 1 |
| 139 | BB-6203 | Ball Bearing | 17x40x12 | 1 |
| 140 | ZX-Q140 | C-Clip | 17 | 1 |

Apron Assembly I

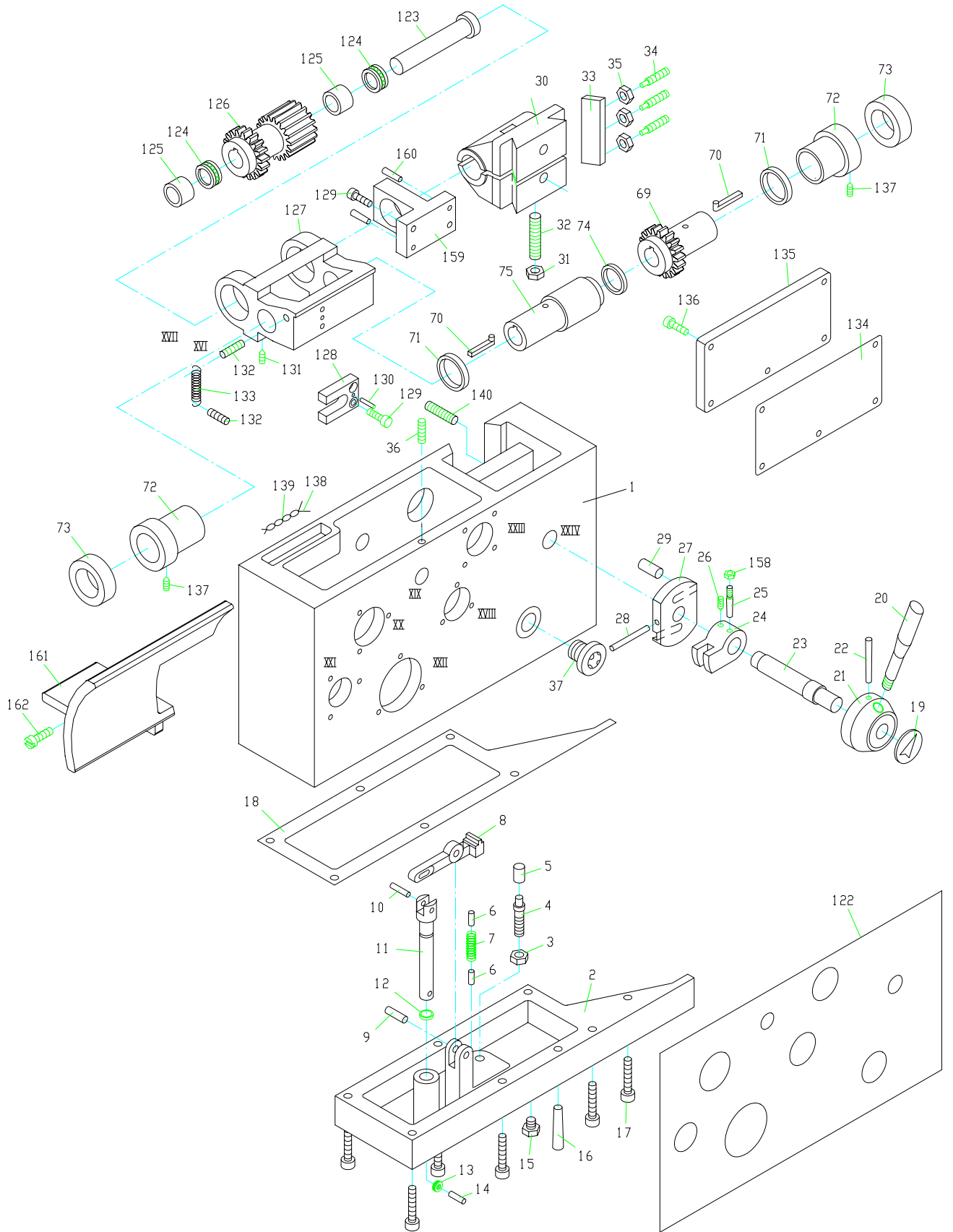

Apron Assembly I

| Index No. | Part No. | Description | Size | Qty. |
|-----------|------------|--|------------|------|
| 1 | TL06101 | Apron Casting | | 1 |
| 2 | TL06103 | Bottom Cover | | 1 |
| 3 | TS-1540072 | Hex Nut | M10 | 1 |
| 4 | ZX-A04 | Flat Head Set Screw | M10x70 | 1 |
| 5 | TL06502 | Cushion Cap | | 1 |
| 6 | ZX-A06 | Pin | 6n6x16 | 2 |
| 7 | ZX-A07 | Tensile Spring | YI1.2x9x50 | 1 |
| 8 | TL06734 | Lever | | 1 |
| 9 | ZX-A09 | Pin | 8n6x30 | 1 |
| 10 | ZX-A10 | Pin | 6n6x18 | 1 |
| 11 | TL06701-A | Pushing Rod | | 1 |
| 12 | ZX-A12 | Oil Seal | 15x2.4 | 1 |
| 13 | BB60016 | Ball Bearing | 6x17x6 | 1 |
| 14 | ZX-A06 | Pin | 6n6x16 | 1 |
| 15 | ZX-A15 | Drain Plug | Z 1/4" | 1 |
| 16 | ZX-B34 | Taper Pin | 5x30 | 2 |
| 17 | TS-1504041 | Hex Socket Cap Screw | M8x20 | 6 |
| 18 | TL06501 | Gasket | | 1 |
| 19 | TL06307 | Sign Plate | | 1 |
| 20 | TL06716 | Lever | | 1 |
| 21 | ZX-06122 | Lever Support | | 1 |
| 22 | ZX-B27 | Taper Pin | 6x60 | 1 |
| 23 | TL06717 | Half Nut Shaft | | 1 |
| 24 | TL06111 | Positioning Block | | 1 |
| 25 | ZX-A25 | Thread Tail Taper Pin | 6x25 | 1 |
| 26 | TS-1523031 | Set Screw | M6x10 | 1 |
| 27 | ZX-06733 | Half Nut Control Plate | | 1 |
| 28 | ZX-A28 | Taper Pin | 6x55 | 1 |
| 29 | ZX-06732 | Pin | | 2 |
| 30 | ZX-06302 | Half Nut (serial # 010611ZX349 and lower) | | 1 |
| | ZX-06302N | New Half Nut (serial # 010618ZX350 and higher) | | 1 |
| 31 | TS-1540072 | Hex Nut | M10 | 1 |
| 32 | ZX-A32 | Cylindrical End Set Screw | M10x60 | 1 |
| 33 | ZX-06121 | Gib | | 1 |
| 34 | ZX-06731 | Cylindrical End Set Screw | | 3 |
| 35 | TS-1540061 | Hex Nut | M8 | 3 |
| 36 | ZX-A36 | Set Screw | M8x32 | 1 |
| 37 | ZX-A37 | Oil Sight Glass | 20 | 1 |
| 69 | TL06727 | Gear (serial # 010611ZX349 and lower) | 2m25T | 1 |
| | TL06727N | New Gear (serial # 010618ZX350 and higher) | 2m25T | 1 |
| 70 | TL06728 | Sliding Key | | 2 |
| 71 | TL06121 | Spacer (serial # 010611ZX349 and lower) | | 2 |
| | TL06121N | New Spacer (serial # 010618ZX350 and higher) | | 2 |
| 72 | TL06304 | Positioning Sleeve (serial # 010611ZX349 and lower) | | 2 |
| | TL06304N | New Positioning Sleeve (serial # 010618ZX350 and higher) | | 2 |
| 73 | ZX-A73 | Ring Seal For Rotating | 3x55 | 2 |
| 74 | ZX-A74 | Oil Seal | 35x3.1 | 1 |
| 75 | TL06729 | Sleeve (serial # 010611ZX349 and lower) | | 1 |
| | TL06729N | New Sleeve (serial # 010618ZX350 and higher) | | 1 |
| 122 | TL06302 | Sign Plate | | 1 |
| 123 | TL06730 | Shaft | | 1 |
| 124 | BB-51104 | Thrust Bearing | | 2 |
| 125 | TL06305 | Sleeve | | 2 |
| 126 | TL06726 | Worm (serial # 010611ZX349 and lower) | | 1 |
| | TL06726N | New Worm (serial # 010618ZX350 and higher) | | 1 |
| 127 | TL06122 | Worm Support (serial # 010611ZX349 and lower) | | 1 |

| Index No. | Part No. | Description | Size | Qty. |
|-----------|------------|--|--------------|------|
| | TL06122N | New Worm Support (serial # 010618ZX350 and higher) | | 1 |
| 128 | TL06720 | Control Plate | | 1 |
| 129 | TS-1514031 | Hex Socket Cap Screw | M6x20 | 4 |
| 130 | ZX-A130 | Taper Pin | 4x20 | 1 |
| 131 | TS-1524031 | Set Screw | M8x12 | 2 |
| 132 | ZX-A132 | Screw | M8x25 | 2 |
| 133 | ZX-A133 | Cylindrical Tensile Spring | LI-1.6x10x58 | 1 |
| 134 | TL06503 | Gasket | | 1 |
| 135 | TL06114 | Back Cover | | 1 |
| 136 | TS-1514011 | Hex Socket Cap Screw | M6x12 | 5 |
| 137 | ZX-A137 | Set Screw | M8x30 | 2 |
| 138 | ZX-A138 | Iron Wire | 1x50 | 2 |
| 139 | ZX-A139 | Oil Conducting Cord | 3x100 | 2 |
| 140 | ZX-A140 | Screw | M10x40 | 1 |
| 158 | TS-1540041 | Hex Nut | M6 | 1 |
| 159 | TL06124 | Bracket | | 1 |
| 160 | ZX-A160 | Taper Pin | 5x25 | 2 |
| 161 | TL06308 | Bracket | | 1 |
| 162 | TS-1503041 | Hex Socket Cap Screw | M6x16 | 1 |

Apron Assembly II

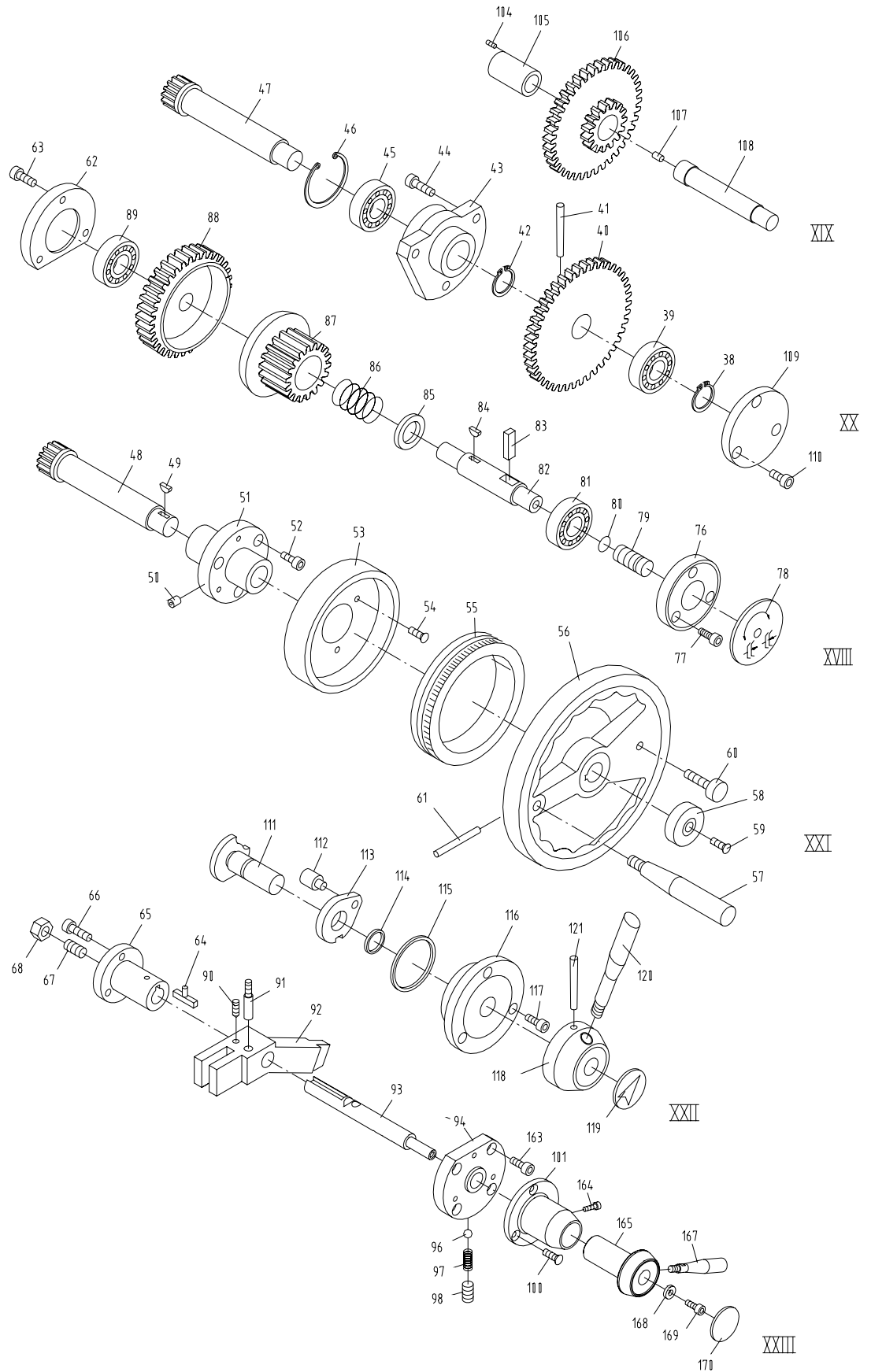

Apron Assembly II

| Index No. | Part No. | Description | Size | Qty. |
|-----------|------------|---|------------|------|
| 38 | ZX-B23 | C-Clip | 20 | 1 |
| 39 | BB-6204 | Ball Bearing | 20x47x14 | 1 |
| 40 | TL06705 | Gear | 2m65T | 1 |
| 41 | ZX-A41 | Taper Pin | 6x40 | 1 |
| 42 | ZX-C40 | C-Clip | 25 | 1 |
| 43 | ZX-06127 | Bearing Support (serial # 010611ZX349 and lower) | | 1 |
| | ZX-06127N | New Bearing Support (serial # 010618ZX350 and higher) | | 1 |
| 44 | TS-1504041 | Hex Socket Cap Screw | M8x18 | 3 |
| 45 | BB-6205Z | Ball Bearing | 25x52x15 | 1 |
| 46 | ZX-A46 | C-Clip | 52 | 1 |
| 47 | TL06704 | Shaft (serial # 010611ZX349 and lower) | 2m14T | 1 |
| | TL06704N | New Shaft (serial # 010618ZX350 and higher) | 2m14T | 1 |
| 48 | TL06706 | Hand Wheel Shaft | 2mx15T | 1 |
| 49 | ZX-H10 | Half Circle Key | 4x16 | 1 |
| 50 | ZX-A50 | Oil Cup | 8 | 1 |
| 51 | TL06104 | Lever Support | | 1 |
| 52 | TS-1514031 | Hex Socket Cap Screw | M6x18 | 3 |
| 53 | TL06105 | Dial Support | | 1 |
| 54 | ZX-A54 | Cross Head Screw | M5x12 | 3 |
| 55 | TL06732 | Dial | | 1 |
| 56 | TL06107 | Hand Wheel | | 1 |
| 57 | ZX-06710 | Shaft Driven Lever | | 1 |
| 58 | TL06709 | Shaft Cover | | 1 |
| 59 | ZX-A54 | Cross Head Screw | M5x12 | 1 |
| 60 | TL06708 | Screw | | 1 |
| 61 | TL06707 | Pin | | 1 |
| 62 | TL06112 | End Cover | | 1 |
| 63 | TS-1514011 | Hex Socket Cap Screw | M6x12 | 3 |
| 64 | TL06733 | T Shaped Flat Key | | 1 |
| 65 | TL06115 | Flange Sleeve | | 1 |
| 66 | TS-1514011 | Hex Socket Cap Screw | M6x12 | 3 |
| 67 | ZX-A67 | Flat End Set Screw | M6x30 | 1 |
| 68 | TS-1540041 | Hex Nut | M6 | 1 |
| 76 | TL06109 | Flange | | 1 |
| 77 | TS-1514011 | Hex Socket Cap Screw | M6x12 | 3 |
| 78 | TL06303 | Sign Plate | | 1 |
| 79 | TL06714 | Adjusting Screw | | 1 |
| 80 | ZX-A80 | Oil Seal | 8x1.9 | 1 |
| 81 | BB-7203 | Ball Bearing | 17x40x12 | 1 |
| 82 | TL06713 | Shaft | | 1 |
| 83 | TL06715 | Adjusting Rod | | 1 |
| 84 | ZX-H10 | Half Circle Key | 4x16 | 1 |
| 85 | TL06712 | Spring Cover | | 1 |
| 86 | ZX-A86 | Spring | YI-5x35x50 | 1 |
| 87 | TL06718 | Gear | 2m28T | 1 |
| 88 | TL06113 | Helical Gear | 2.5m40T | 1 |
| 89 | BB7006/P6 | Ball Bearing | 30x55x13 | 1 |
| 90 | TS-1523031 | Set Screw | M6x10 | 1 |
| 91 | ZX-A25 | Thread Tail Taper Pin | 6x25 | 1 |
| 92 | TL06110 | Fork | | 1 |
| 93 | ZX-06721E | Control Rod | | 1 |
| 94 | ZX-06116E | Lever Support | | 1 |
| 96 | ZX-H5 | Steel ball | 8 | 1 |
| 97 | ZX-A97 | Spring | YI-1x7x25 | 1 |
| 98 | ZX-A98 | Flat Head Set Screw | M10x16 | 1 |

| Index No. | Part No. | Description | Size | Qty. |
|-----------|------------|-------------------------------|-------------|------|
| 100 | ZX-A100 | Cross Head Screw | M5x10 | 3 |
| 101 | TL06117E | Cover | | 1 |
| 104 | ZX-A104 | Flat Head Set Screw | M4x8 | 1 |
| 105 | TL06301 | Sleeve | | 1 |
| 106 | TL06710 | Gear | 2m21T/2m57T | 1 |
| 107 | ZX-A107 | Pin | 6n6x8 | 1 |
| 108 | TL06711 | Shaft | | 1 |
| 109 | TL06108 | End Cover | | 1 |
| 110 | TS-1514011 | Hex Socket Cap Screw | M6x12 | 3 |
| 111 | TL06723 | Control Shaft | | 1 |
| 112 | TL06725 | Pin | | 1 |
| 113 | TL06724 | Control Block | | 1 |
| 114 | ZX-A114 | Oil Seal | 20x2.4 | 1 |
| 115 | ZX-A115 | Oil Seal | 50x3.1 | 1 |
| 116 | TL06119 | Lever Flange | | 1 |
| 117 | TS-1514011 | Hex Socket Cap Screw | M6x12 | 3 |
| 118 | TL06118 | Lever Support | | 1 |
| 119 | TL06307 | Sign Plate | | 1 |
| 120 | TL06716 | Lever | | 1 |
| 121 | ZX-B27 | Taper Pin | 6x60 | 1 |
| 163 | ZX-A163E | Cross Head Screw | M6x18 | 4 |
| 164 | ZX-A164E | Hexagon socket cap head Screw | M4x6 | 1 |
| 165 | ZX-06125E | Lever | | 1 |
| 167 | ZX-06737E | Lever | | 1 |
| 168 | ZX-06736E | Washer | | 1 |
| 169 | ZX-A169E | Cross Head Screw | M5x10 | 1 |
| 170 | ZX-06310E | Sign Plate | | 1 |

Apron Assembly III

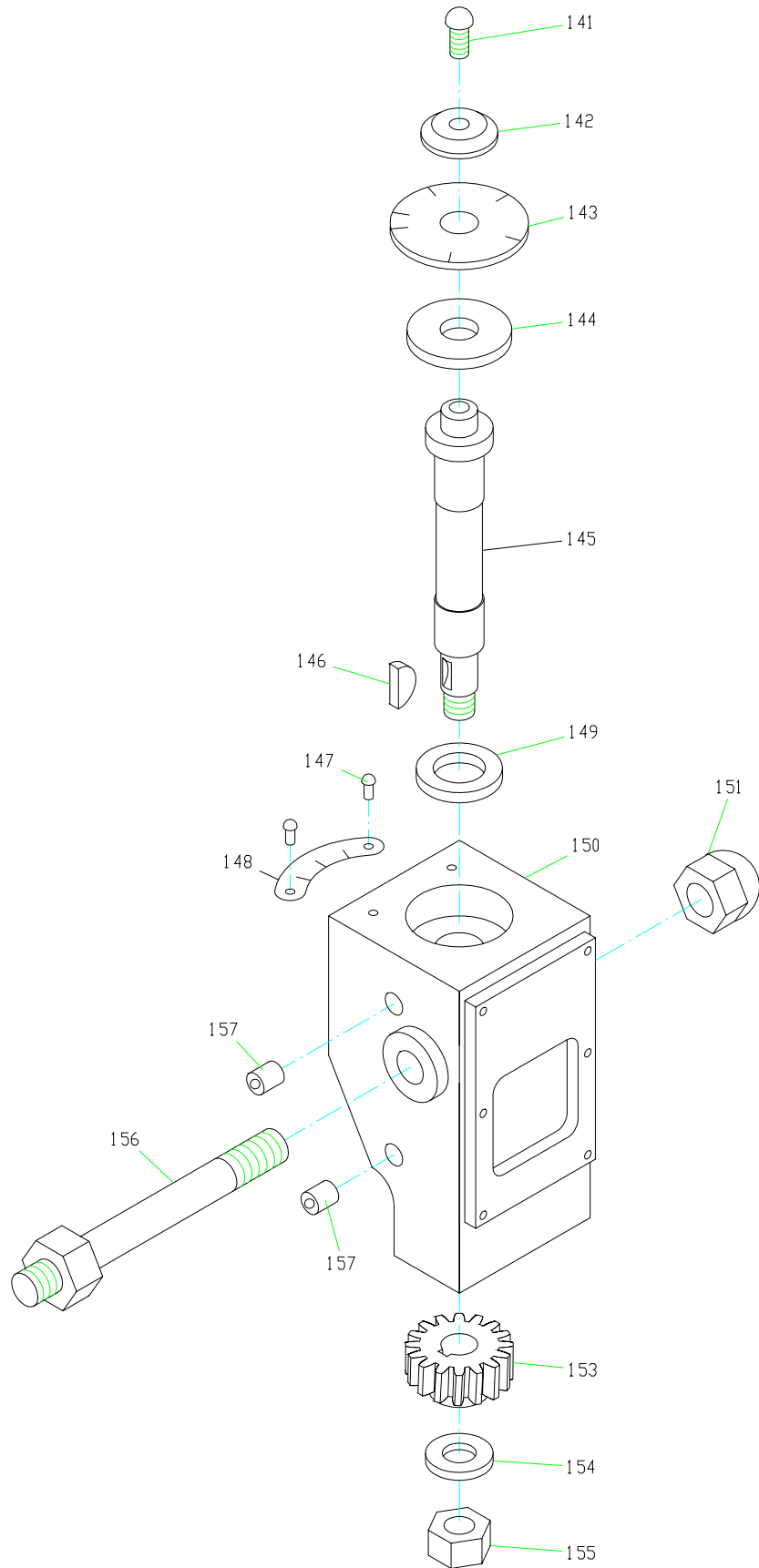

Apron Assembly III

| Index No. | Part No. | Description | Size | Qty. |
|-----------|------------|------------------------|-------|------|
| 141 | ZX-A141 | Half Round Head Screw | M6x18 | 1 |
| 142 | ZX-11704 | Washer | | 1 |
| 143 | ZX-11301 | Dial | | 1 |
| 144 | ZX-11105 | Adjusting Washer | | 1 |
| 145 | ZX-11701 | Shaft | | 1 |
| 146 | ZX-H10 | Half Circle Key | 4x16 | 1 |
| 147 | ZX-A147 | Half Round Head Screw | M3x6 | 2 |
| 148 | ZX-11303 | Positioning Sign Plate | | 1 |
| 149 | ZX-11703 | Adjusting Washer | | 1 |
| 150 | ZX-11101 | Casting | | 1 |
| 151 | ZX-A151 | Acorn Nut | M12 | 1 |
| 153 | ZX-11102E | Helical Gear | 2m15T | 1 |
| 154 | TS-1550071 | Flat Washer | M10 | 1 |
| 155 | TS-1540072 | Hex Nut | M10 | 1 |
| 156 | ZX-11702 | Bolt | | 1 |
| 157 | ZX-A157 | Oil Cup | 8 | 2 |

Carriage Assembly

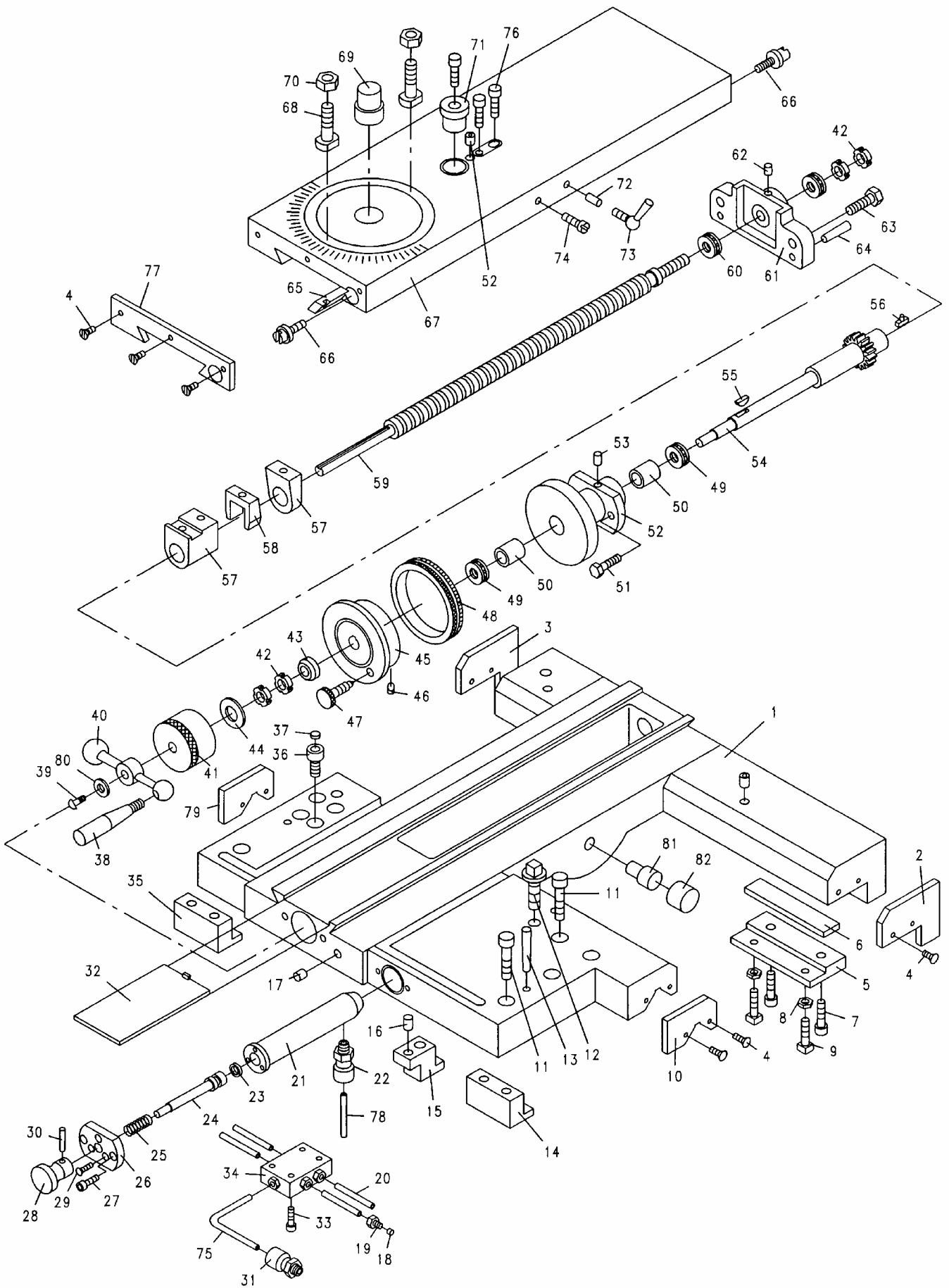

Carriage Assembly

| Index No. | Part No. | Description | Size | Qty. |
|-----------|------------|---------------------------|-----------|------|
| 1 | ZX-04101A | Saddle Casting | | 1 |
| 2 | ZX-04505 | Wipe Plate | | 1 |
| 3 | ZX-04504 | Wipe Plate | | 1 |
| 4 | ZX-H211 | Countersunk Head Screw | M5x16 | 11 |
| 5 | ZX-04724 | Clamping Block | | 2 |
| 6 | ZX-04113 | Lining Plate | | 2 |
| 7 | TS-1516031 | Hex Socket Cap Screw | M10x30 | 4 |
| 8 | TS-1540061 | Hex Nut | M8 | 4 |
| 9 | ZX-CA09 | Square Set Screw | M8x20 | 4 |
| 10 | ZX-04506 | Wipe Plate | | 1 |
| 11 | TS-1505071 | Hex Socket Cap Screw | M10x45 | 8 |
| 12 | ZX-CA12 | Square Cap Bolt | M12x60 | 1 |
| 13 | ZX-CA13 | Taper Pin | 8x60 | 2 |
| 14 | ZX-04729 | Clamping Block | | 1 |
| 15 | ZX-04730 | Locking Plate | | 1 |
| 16 | ZX-CA16 | Pin | 4n6x12 | 1 |
| 17 | ZX-04772 | Blocking Piece | | 1 |
| 18 | ZX-CA18 | Fitting Joint Seal | A4 | 8 |
| 19 | ZX-CA19 | Hollowed Bolt | A4 | 8 |
| 20 | ZX-CA20 | Copper Tube | | 4 |
| 21 | ZX-04782 | Manual Oil Pump Casting | | 1 |
| 22 | ZX-04781A | In Valve | | 1 |
| 23 | ZX-CA23 | Oil Ring | 15x2.4 | 1 |
| 24 | ZX-04784 | Piston | | 1 |
| 25 | ZX-CA25 | Spring | 1.2x14x65 | 1 |
| 26 | ZX-04785 | Oil Pump Cover | | 1 |
| 27 | TS-1513031 | Hex Socket Cap Screw | M5x16 | 2 |
| 28 | ZX-04783 | Lever | | 1 |
| 29 | ZX-CA29 | Countersunk Head Screw | M4x16 | 3 |
| 30 | ZX-A130 | Taper Pin | 4x20 | 1 |
| 31 | ZX-04781B | Out Valve | | 1 |
| 32 | ZX-04716 | Chip Guard | | 1 |
| 33 | ZX-CA33 | Slotted Cheese Head Screw | M5x20 | 4 |
| 34 | ZX-04780 | Oil Distributor | | 1 |
| 35 | ZX-04740 | Clamping Block | | 1 |
| 36 | ZX-04750 | Oil Cap | | 1 |
| 37 | ZX-04301 | Oil Indicator Cap | | 1 |
| 38 | ZX-04721 | Lever | | 1 |
| 39 | ZX-CA39 | Cross Head Screw | M5x16 | 1 |
| 40 | ZX-04720 | Handle | | 1 |
| 41 | ZX-04769 | Sleeve | | 1 |
| 42 | ZX-CA42 | Round Nut | M12x1.25 | 4 |
| 43 | ZX-04719 | Lining | | 1 |
| 44 | ZX-04770 | Disc Spring | | 1 |
| 45 | ZX-04108 | Flat Pan | | 1 |
| 46 | ZX-04790 | Pushing Rod | | 1 |
| 47 | ZX-04789 | Screw | | 1 |
| 48 | ZX-04717 | Dial | | 1 |
| 49 | BB-51102 | Thrust Bearing | 15x28x9 | 2 |
| 50 | ZX-04111 | Sleeve | | 2 |
| 51 | TS-1490041 | Hex Cap Bolt | M8x25 | 2 |
| 52 | ZX-04109 | Screw Support | | 1 |
| 53 | ZX-CA53 | Oil Cup | 8 | 2 |
| 54 | ZX-04707-1 | Gear Sliding Sleeve | 2m16T | 1 |
| 55 | ZX-H10 | Half Circle Key | 4x16 | 1 |
| 56 | ZX-04751 | Flat Key | | 1 |

| Index No. | Part No. | Description | Size | Qty. |
|-----------|-------------|--|---------|------|
| 57 | ZX-04302 | Nut Assembly | | 1 |
| 58 | ZX-04748 | Wedge | | 1 |
| 59 | ZX-04707-2 | Lead Screw | | 1 |
| 60 | BB-51101/P6 | Thrust Bearing | 12x26x9 | 2 |
| 61 | ZX-04116 | Bracket | | 1 |
| 62 | ZX-CA62 | Oil Cup | 6 | 1 |
| 63 | TS-1491041 | Cap Screw | M10x30 | 2 |
| 64 | ZX-CA64 | Taper Pin | 8x30 | 2 |
| 65 | ZX-04731 | Cross Slide Gib | | 1 |
| 66 | ZX-04725C | Screw | | 2 |
| 67 | ZX-04102A | Cross Slide | | 1 |
| 68 | ZX-04714 | Screw (for 18" models, T- Slot) | | 2 |
| | ZX-04714C | Screw (for 14"/16" models, T-Slot) | | 2 |
| 69 | ZX-04732 | Pin | | 1 |
| 70 | TS-1540081 | Hex Nut | M12 | 2 |
| 71 | ZX-04709 | Sleeve | | 1 |
| 72 | ZX-04304 | Pressing Pin | 1 | 1 |
| 73 | ZX-04746 | Screw | | 1 |
| 74 | ZX-04786 | Set Screw | | 1 |
| 75 | ZX-CA75 | Long Copper Tube | | 1 |
| 76 | TS-1504051 | Socket Head Cap Screw | M8x22 | 3 |
| 77 | ZX-04502 | Wipe Plate | | 1 |
| 78 | ZX-CA78 | Copper Tube | | 6 |
| 79 | ZX-04503 | Wipe Plate | | 1 |
| 80 | ZX-04771 | Lining | | 1 |
| 81 | ZX-04788 | Stop Pin | | 1 |
| 82 | ZX-04507 | Stop Pin Cap | | 1 |
| | ZX-CSNA | Crossfeed Screw & Nut Assy. (includes # 57- 59. for 14/16/18") | | |
| | ZX-CDA | Crossfeed Dial Assy. (includes # 41-50, 51-56. for 14/16/18") | | |

Carriage Stop Assembly

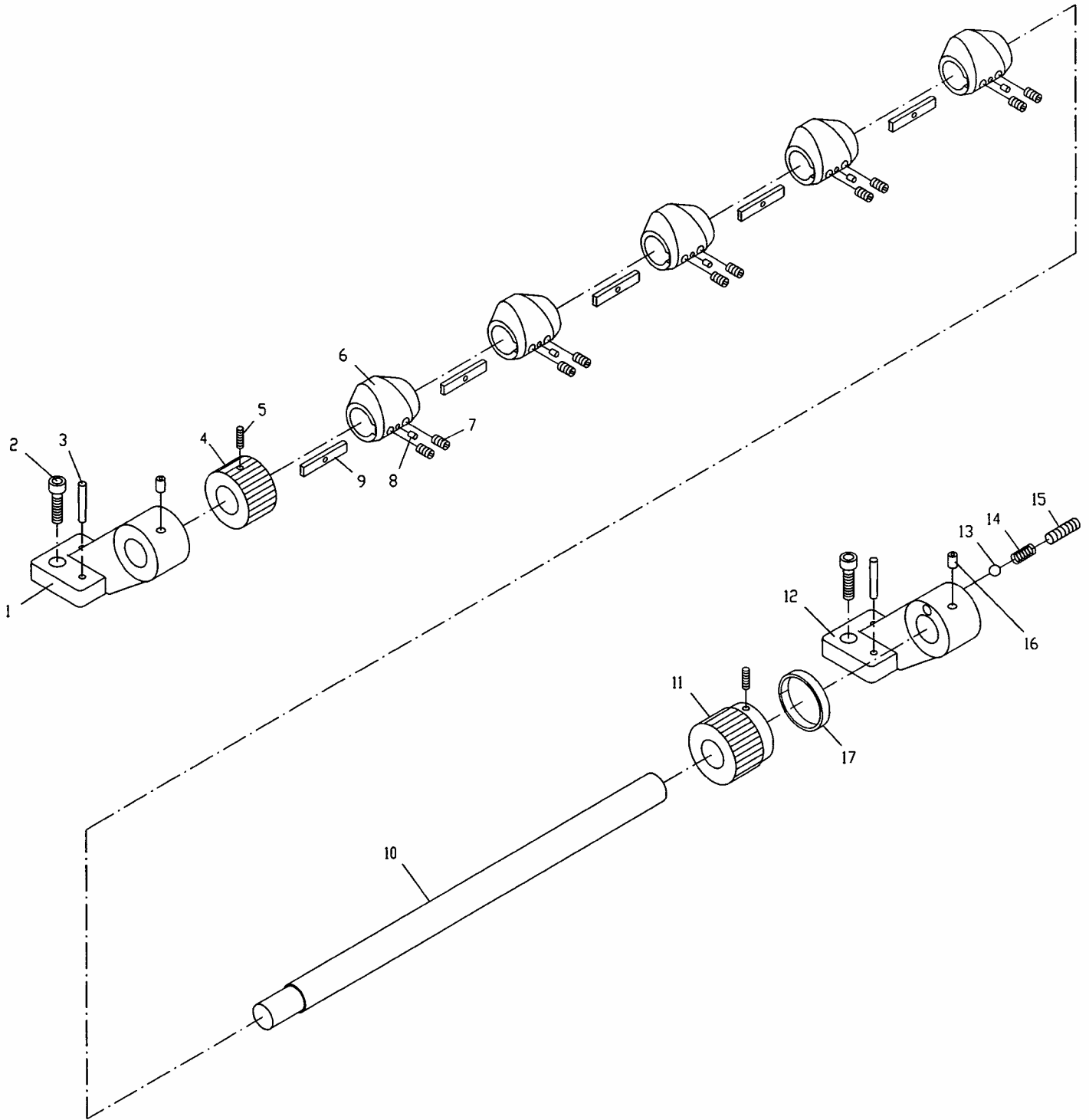

Carriage Stop Assembly

| Index No. | Part No. | Description | Size | Qty. |
|--------------|-------------|---|--------|------|
| 1 | ZX-26101 | Left Support | | 1 |
| 2 | TS-1504041 | Hex Socket Cap Screw | M8x20 | 4 |
| 3 | ZX-C34 | Taper Pin | 6x30 | 4 |
| 4 | ZX-26704 | Control Ring | | 1 |
| 5 | TS-1523031 | Set Screw | M6x10 | 2 |
| 6 | ZX-26702 | Eccentric Travel Setting Ring | | 5 |
| 7 | ZX-H66 | Flat End Set Screw | M6x10 | 10 |
| 8 | ZX-CS08 | Pin | 4n6x10 | 5 |
| 9 | ZX-26703 | Locking Key | | 5 |
| 10 | ZX-26701A | Travel Setting Rod (for 1440/1640/1840ZX) | | 1 |
| | ZX-26701B | Travel Setting Rod (for 1460/1660/1860ZX) | | 1 |
| | ZX-26701C | Travel Setting Rod (for 1880ZX) | | 1 |
| 11 | ZX-26705 | Control Ring | | 1 |
| 12 | ZX-26104 | Right Support | | 1 |
| 13 | ZX-H5 | Steel Ball | 8 | 1 |
| 14 | ZX-CS14 | Compression Spring | 2x8x25 | 1 |
| 15 | ZX-CS15 | Flat Head Set Screw | M10x12 | 1 |
| 16 | ZX-CS16 | Oil Cup | 8 | 2 |
| 17 | ZX-26301 | Dial | | 1 |

Four Way Tool Post

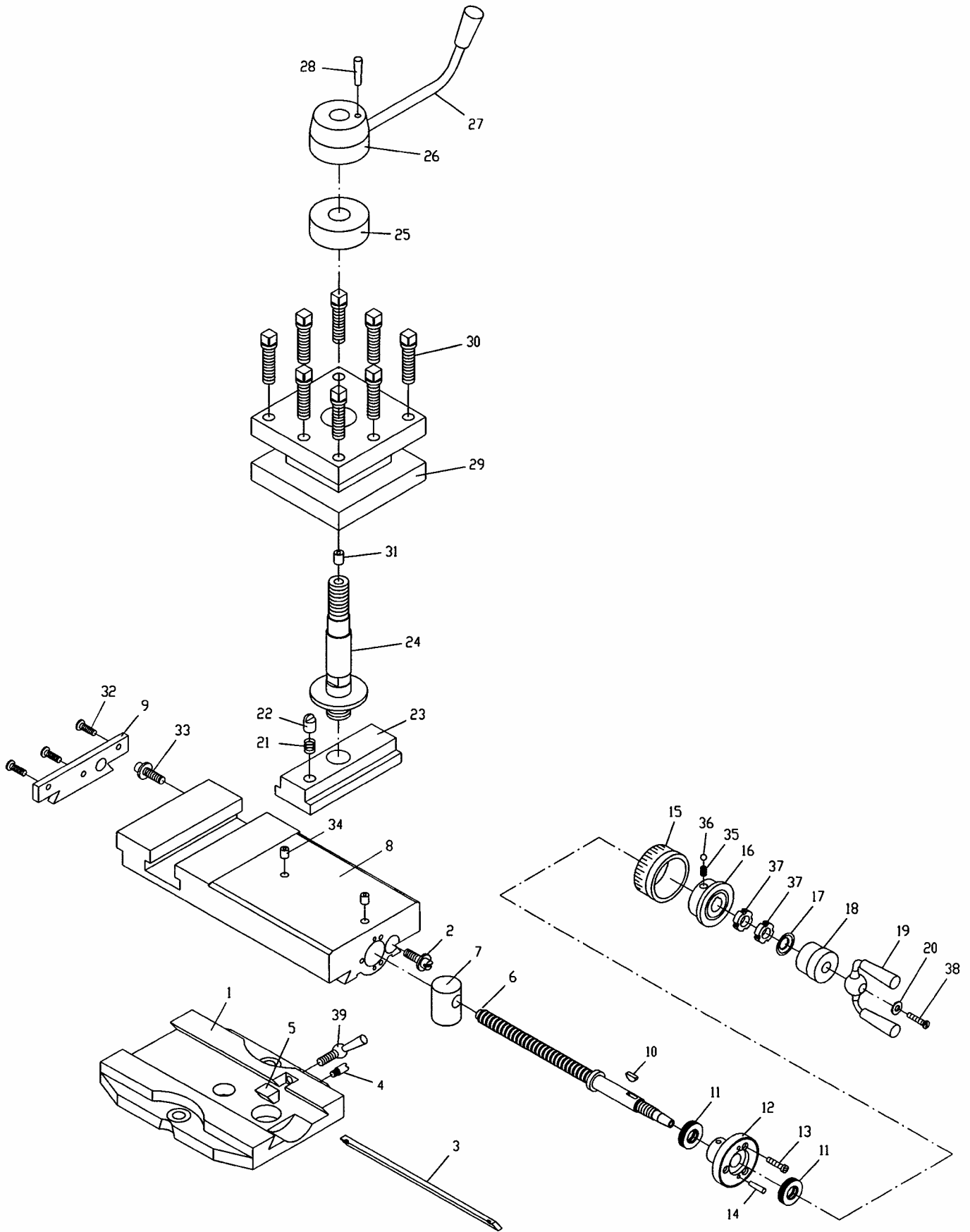

Four Way Tool Post

| Index No. | Part No. | Description | Size | Qty. |
|-----------|------------|--|----------|------|
| 1 | ZX-04103A | Revolving Plate (for 14" models) | | 1 |
| | ZX-04103B | Revolving Plate (for 16" models) | | 1 |
| | ZX-04103C | Revolving Plate (for 18" models) | | 1 |
| 2 | ZX-04725 | Screw | | 1 |
| 3 | ZX-04710 | Gib | | 1 |
| 4 | ZX-04786 | Screw | | 1 |
| 5 | ZX-04303 | Pressing Block | | 1 |
| 6 | ZX-04706 | Lead Screw | | 1 |
| 7 | ZX-04106A | Nut | | 1 |
| 8 | ZX-04107A | Top Slide (for 14" models) | | 1 |
| | ZX-04107B | Top Slide (for 16"/18" models) | | 1 |
| 9 | ZX-04501 | Wipe Plate | | 1 |
| 10 | ZX-F10 | Half Circle Key | 3x13 | 1 |
| 11 | BB-51102 | Thrust Bearing | 15x28x9 | 2 |
| 12 | ZX-04115 | Sleeve | | 1 |
| 13 | ZX-F13 | Slotted Cheese Head Screw | M5x12 | 3 |
| 14 | ZX-F14 | Taper Pin | 3x18 | 2 |
| 15 | ZX-04727 | Dial | | 1 |
| 16 | ZX-04114 | Sleeve | | 1 |
| 17 | ZX-04768 | Disc Spring | | 1 |
| 18 | ZX-04767 | Sleeve | | 1 |
| 19 | ZX-04726 | Handle | | 1 |
| 20 | ZX-04771 | Lining | | 1 |
| 21 | ZX-04763 | Spring | 0.8x6x25 | 1 |
| 22 | ZX-04787 | Positioning Block | | 1 |
| 23 | ZX-04752A | T-Slot Nut | | 1 |
| 24 | ZX-04754 | Shaft | | 1 |
| 25 | ZX-04759 | Adjusting Lining Sheet | | 1 |
| 26 | ZX-04110 | Lever Support | | 1 |
| 27 | ZX-04753 | Handle | | 1 |
| 28 | ZX-Q66 | Taper Pin | 5x35 | 1 |
| 29 | ZX-04713A | Tool Post (for 14" models) | | 1 |
| | ZX-04713B | Tool post (for 16"/18" models) | | 1 |
| 30 | ZX-F30A | Clamping Screw (for 16"/18" models) | M12x45 | 8 |
| | ZX-F30B | Clamping Screw (for 14" models) | M12x50 | 8 |
| 31 | ZX-F31 | Oil Cup | 8 | 1 |
| 32 | ZX-H211 | Countersunk Head Screw | M5x16 | 3 |
| 33 | ZX-04725C | Screw | | 1 |
| 34 | ZX-F34 | Oil Cup | 8 | 2 |
| 35 | ZX-F35 | Spring | 0.7x5x9 | 1 |
| 36 | ZX-F36 | Steel Ball | 6 | 1 |
| 37 | ZX-F37 | Round Nut | M12x1.25 | 2 |
| 38 | ZX-CA39 | Cross Head Screw | M5x16 | 1 |
| 39 | ZX-04746K | Screw Wrench | | 1 |
| | ZX-TA14 | Toolholder Assy. 14" (includes # 29 & 30) | | |
| | ZX-TA16/18 | Toolholder Assy. 16/18" (includes # 29 & 30) | | |
| | ZX-CPA14 | Compound Assy. 14" (includes # 1-20,32-39) | | |
| | ZX-CPA16 | Compound Assy. 16" (includes # 1-20,32-39) | | |
| | ZX-CPA18 | Compound Assy. 18" (includes # 1-20,32-39) | | |

Tailstock Assembly I

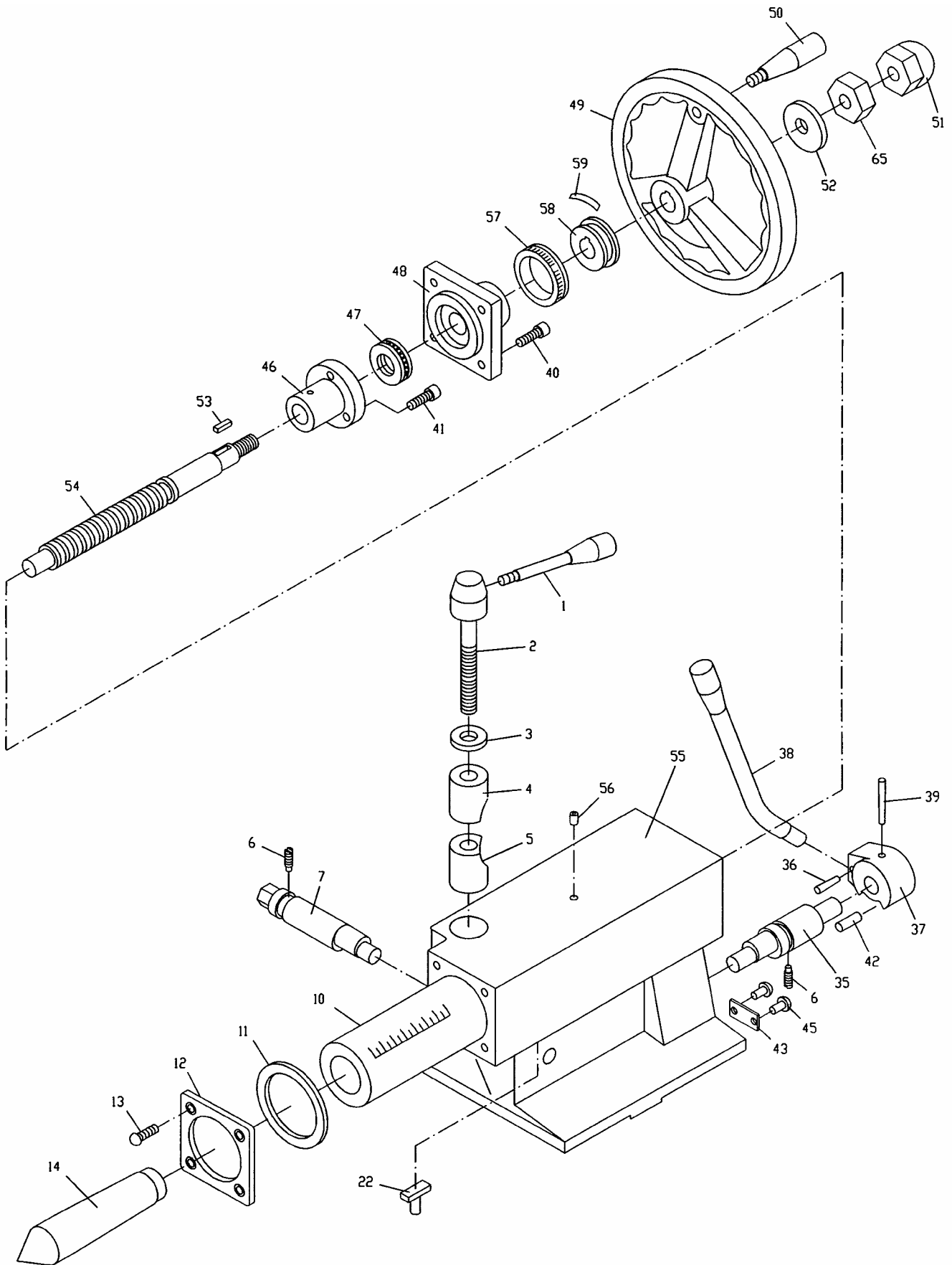

Tailstock Assembly I

| Index No. | Part No. | Description | Size | Qty. |
|-----------|------------|---------------------------------------|----------|------|
| 1 | ZX-03711 | Handle | | 1 |
| 2 | ZX-03717 | Lever Support | | 1 |
| 3 | ZX-03718 | Washer | | 1 |
| 4 | ZX-03719 | Clamping Block | | 1 |
| 5 | ZX-03720 | Clamping Block | | 1 |
| 6 | ZX-T06 | Cylindrical End Set Screw | M8x14 | 2 |
| 7 | ZX-03712 | Eccentric Shaft | | 1 |
| 10 | ZX-03701A | Center Sleeve (for 18" models) | | 1 |
| | ZX-03701B | Center Sleeve (for 14"/16" models) | | 1 |
| 11 | ZX-T11 | Ring Seal | 75x2.65 | 1 |
| 12 | ZX-03703 | Front Cover | | 1 |
| 13 | ZX-T13 | Cross Recessed Countersunk Head Screw | M5x10 | 4 |
| 14 | ZX-T14A | Center Morse (for 18" models) | No.5 | 1 |
| | ZX-T14B | Center Morse (for 14"/16" models) | No.4 | 1 |
| 22 | ZX-03702 | Positioning Block | | 1 |
| 35 | ZX-03714 | Eccentric Shaft | | 1 |
| 36 | ZX-T36 | Taper Pin | 6x32 | 1 |
| 37 | ZX-03104 | Lever Sleeve | | 1 |
| 38 | ZX-03709 | Lock handle | | 1 |
| 39 | ZX-A28 | Taper Pin | 6x55 | 1 |
| 40 | TS-1504041 | Hex Socket Cap Screw | M8x20 | 4 |
| 41 | TS-1515031 | Hex Socket Cap Screw | M8x22 | 3 |
| 42 | ZX-T42 | Pin | 10n6x22 | 1 |
| 43 | ZX-03302 | Sign Plate | | 1 |
| 45 | ZX-T45 | Nail | 3x8 | 4 |
| 46 | ZX-03105 | Nut | | 1 |
| 47 | BB-51205 | Thrust Ball Bearing | 25x47x15 | 1 |
| 48 | ZX-03104 | Back Cover | | 1 |
| 49 | ZX-03103 | Hand Wheel | | 1 |
| 50 | ZX-03707 | Lever | | 1 |
| 51 | ZX-T51 | Acorn Nut | M16 | 1 |
| 52 | TS-2360161 | Flat Washer | B16 | 1 |
| 53 | ZX-T53 | Key | 6x40 | 1 |
| 54 | ZX-03710A | Lead Screw (for 18" models) | | 1 |
| | ZX-03710B | Lead Screw (for 14"/16" models) | | 1 |
| 55 | ZX-03101A | Tailstock Casting (for 18" models) | | 1 |
| | ZX-03101B | Tailstock Casting (for 16" models) | | 1 |
| | ZX-03101C | Tailstock Casting (for 14" models) | | 1 |
| 56 | ZX-T56 | Oil Cup | 8 | 1 |
| 57 | ZX-03708 | Dial | | 1 |
| 58 | ZX-03706 | Sleeve | | 1 |
| 59 | ZX-03711C | Spring Leaf | | 1 |
| 65 | TS-2310162 | Nut | M16 | 1 |

Tailstock Assembly II

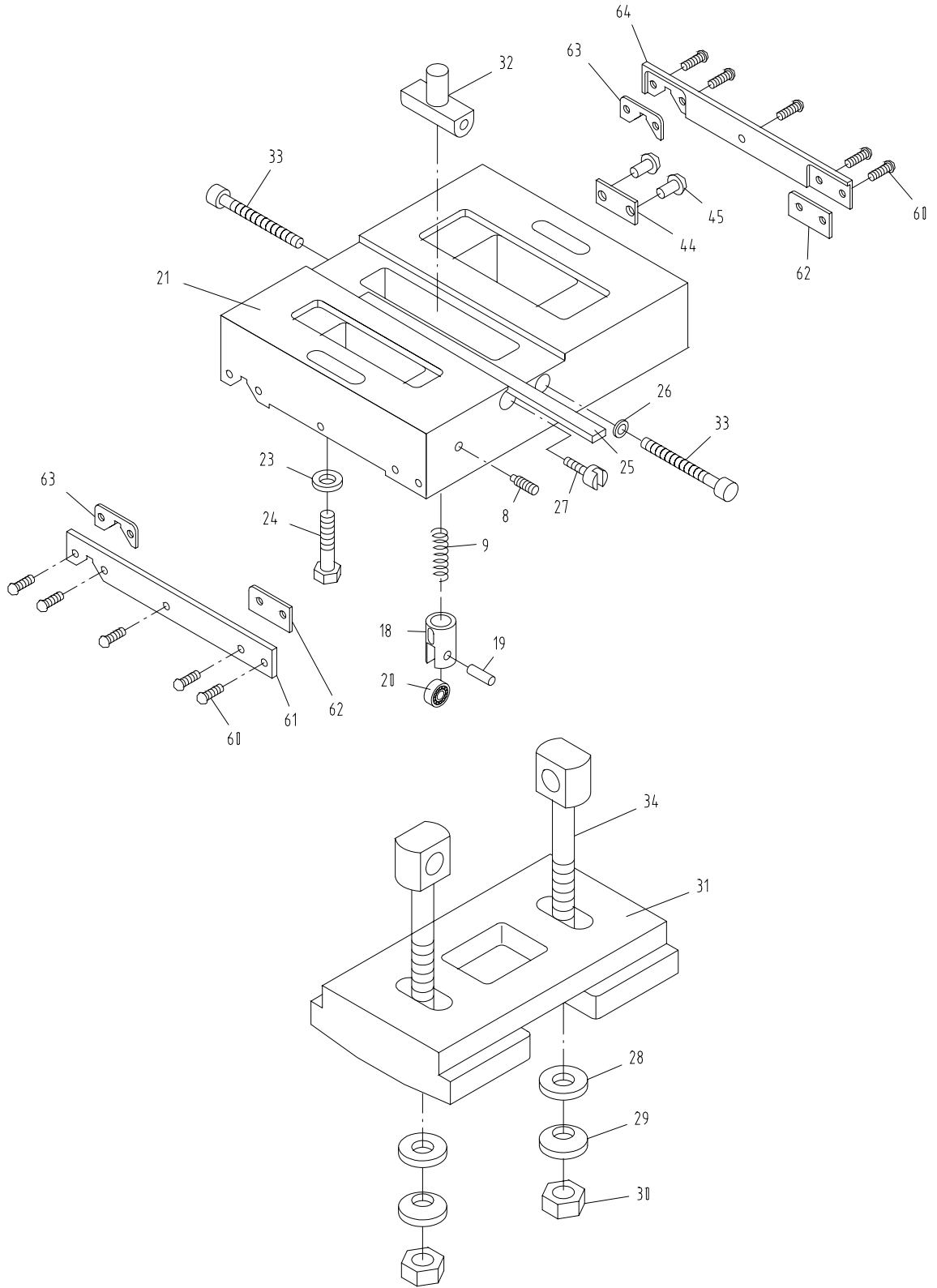

Tailstock Assembly II

| Index No. | Part No. | Description | Size | Qty. |
|-----------|------------|---|--------|------|
| 8 | ZX-T08 | Flat End Set Screw (Except in 14" models) | M6x18 | 4 |
| 9 | ZX-T09E | Spring | | 1 |
| 18 | ZX-03714 | Bearing Support (Except in 14" models) | | 4 |
| 19 | ZX-03715 | Small Axle (Except in 14" models) | | 4 |
| 20 | ZX-T20 | Ball Bearing (Except in 14" models) | 7x19x6 | 4 |
| 21 | ZX-03102A | Sliding Base (for 18" models) | | 1 |
| | ZX-03102B | Sliding Base (for 16" models) | | 1 |
| | ZX-03102C | Sliding Base (for 14" models) | | 1 |
| 23 | TS-1550071 | Flat Washer | M10 | 2 |
| 24 | TS-1491151 | Hex Cap Bolt (for 18" models) | M10x90 | 2 |
| | TS-1491121 | Hex Cap Bolt (for 16" models) | M10x70 | 2 |
| | TS-1491081 | Hex Cap Bolt (for 14" models) | M10x50 | 2 |
| 25 | ZX-03704 | Gib | | 1 |
| 26 | ZX-03721C | Spherical Washer | | 2 |
| 27 | ZX-03718C | Adjusting Screw | | 2 |
| 28 | ZX-T28 | Taper Washer | 16 | 2 |
| 29 | ZX-T29 | Spherical Washer | 16 | 2 |
| 30 | TS-2310162 | Hex Nut | M16 | 2 |
| 31 | ZX-03106 | Clamping Bracket | | 1 |
| 32 | ZX-03105C | Nut | | 1 |
| 33 | ZX-T33 | Hex Socket Cap Screw | M8x85 | 2 |
| 34 | ZX-03705A | Pulling Rod (for 18" models) | | 2 |
| | ZX-03705B | Pulling Rod (for 16" models) | | 2 |
| | ZX-03705C | Pulling Rod (for 14" models) | | 2 |
| 44 | ZX-03303 | Sign Plate | | 1 |
| 45 | ZX-T45 | Nail | 3x8 | 4 |
| 60 | ZX-T60 | Half Round Head Screw | M5 x12 | 10 |
| 61 | ZX-03721 | Plate | | 1 |
| 62 | ZX-03502 | Wipe Plate | | 2 |
| 63 | ZX-03503 | Wipe Plate | | 2 |
| 64 | ZX-03716 | Plate | | 1 |
| | ZX-TSA14 | Tailstock Assy. 14" (includes # 1-13,15-65) | | 1 |
| | ZX-TSA16 | Tailstock Assy. 16" (includes # 1-13,15-65) | | 1 |
| | ZX-TSA18 | Tailstock Assy. 18" (includes # 1-13,15-65) | | 1 |

Steady Rest Assembly

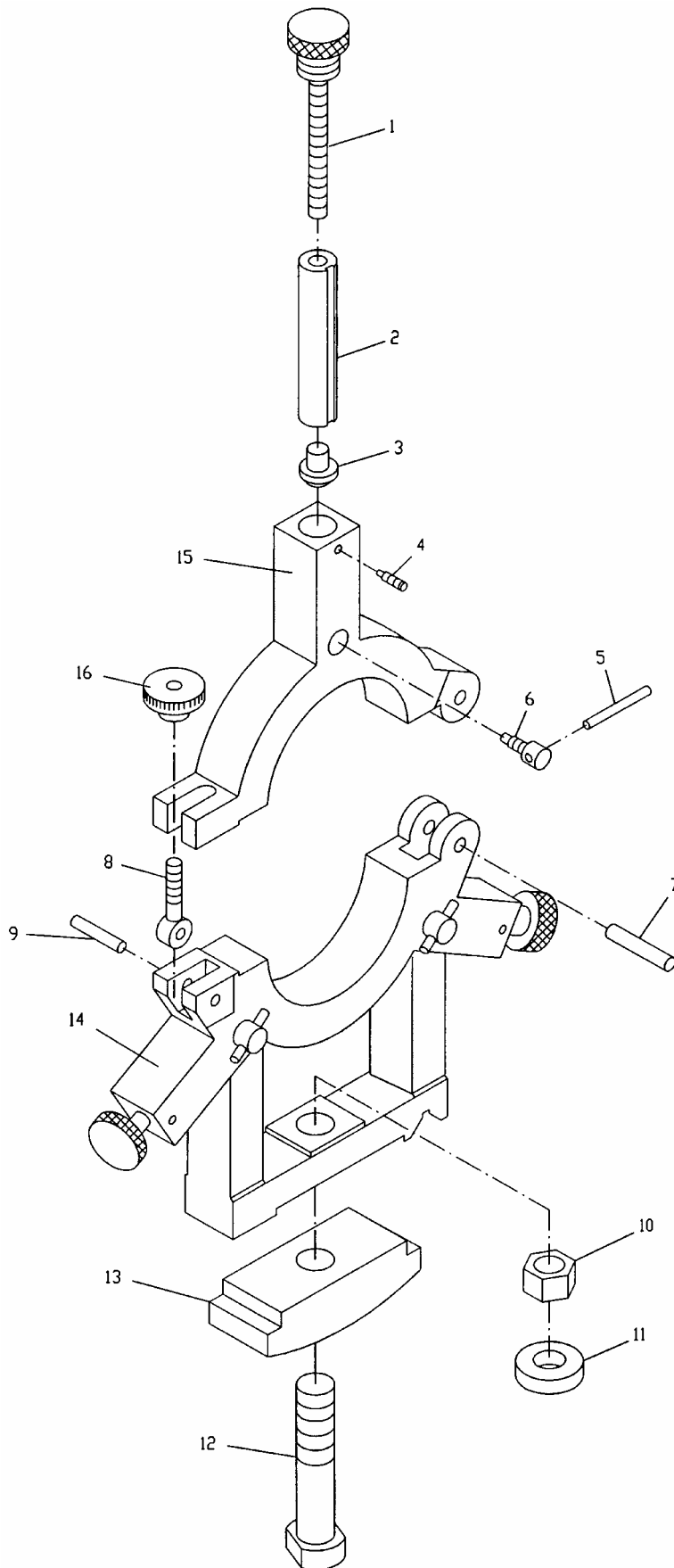

Steady Rest Assembly

| Index No. | Part No. | Description | Size | Qty. |
|-----------|------------|--|---------------|------|
| 1 | ZX-10702A | Screw (for 14" models) | | 3 |
| | ZX-10702B | Screw (for 16" models) | | 3 |
| | ZX-10702C | Screw (for 18" models) | | 3 |
| 2 | ZX-10704D | Sliding Sleeve (for 14") | 0.78" - 4.33" | 3 |
| | ZX-10705D | Sliding Sleeve (for 14") | 3.5" - 7" | 3 |
| | ZX-10705D | Sliding Sleeve (for 16"/18" models) | | 3 |
| 3 | ZX-10301D | Pushing Block (for 14" models) | | 3 |
| | | Pushing Block (for 16"/18" models) | | 3 |
| 4 | ZX-SR04 | Slotted Set Screw | M6x20 | 3 |
| 5 | ZX-10705 | Lever | | 3 |
| 6 | ZX-10706 | Locking Screw | | 3 |
| 7 | ZX-C36 | Pin | 10n6x40 | 1 |
| 8 | ZX-10701 | Hinge Screw | | 1 |
| 9 | ZX-SR9 | Pin | 8n6x40 | 1 |
| 10 | ZX-SR10 | Hex Nut | M20 | 1 |
| 11 | ZX-SR11 | Flat Washer | 20 | 1 |
| 12 | ZX-10708 | Tightening Screw | | 1 |
| 13 | ZX-10103D | Clamping Plate | | 1 |
| 14 | ZX-10101A | Lower Part of Steady Rest (for 14" models) | | 1 |
| | ZX-10101B | Lower Part of Steady Rest (for 16" models) | | 1 |
| | ZX-10101C | Lower Part of Steady Rest (for 18" models) | | 1 |
| 15 | ZX-10102AS | Upper Part of Steady Rest (for 14" models) | | 1 |
| | ZX-10102BS | Upper Part of Steady Rest (for 16"/18" models) | | 1 |
| 16 | ZX-SR16 | Round Nut | M10 | 1 |
| | ZX-SRA14 | Steady Rest Assy. 14" (includes # 1-16) | | |
| | ZX-SRA16 | Steady Rest Assy. 16" (includes # 1-16) | | |
| | ZX-SRA18 | Steady Rest Assy. 18" (includes # 1-16) | | |

Follow Rest Assembly

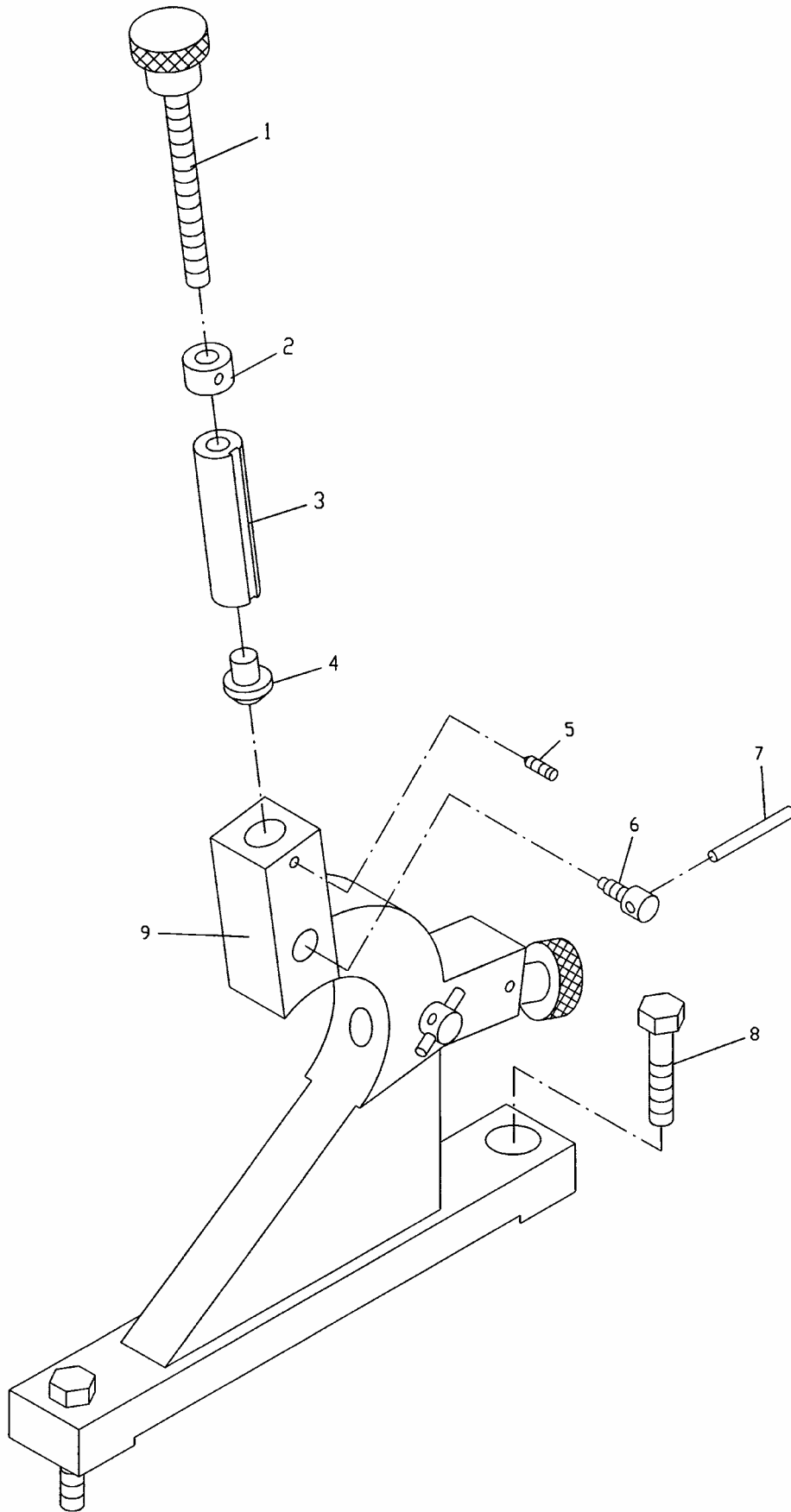

Follow Rest Assembly

| Index No. | Part No. | Description | Size | Qty. |
|-----------|-----------|---|--------|------|
| 1 | ZX-10710 | Screw | | 2 |
| 2 | ZX-10704 | Nut | | 2 |
| 3 | ZX-10707 | Sliding Sleeve | | 2 |
| 4 | ZX-10301 | Supporting Piece | | 2 |
| 5 | ZX-FR05 | Slotted Set Screw | M6x10 | 2 |
| 6 | ZX-10705 | Locking Screw | | 2 |
| 7 | ZX-10706 | Handle | | 2 |
| 8 | ZX-FR08 | Hex Cap Bolt | M12x55 | 2 |
| 9 | ZX-10102A | Follow Rest Casting (for 14" models) | | 1 |
| | ZX-10102B | Follow Rest Casting (for 16" models) | | 1 |
| | ZX-10102C | Follow Rest Casting (for 18" models) | | 1 |
| | ZX-FRA14 | Follow Rest Assy.14" (includes # 1-7,9) | | |
| | ZX-FRA16 | Follow Rest Assy.16" (includes # 1-7,9) | | |
| | ZX-FRA18 | Follow Rest Assy.18" (includes # 1-7,9) | | |

Coolant & Work Light Assembly

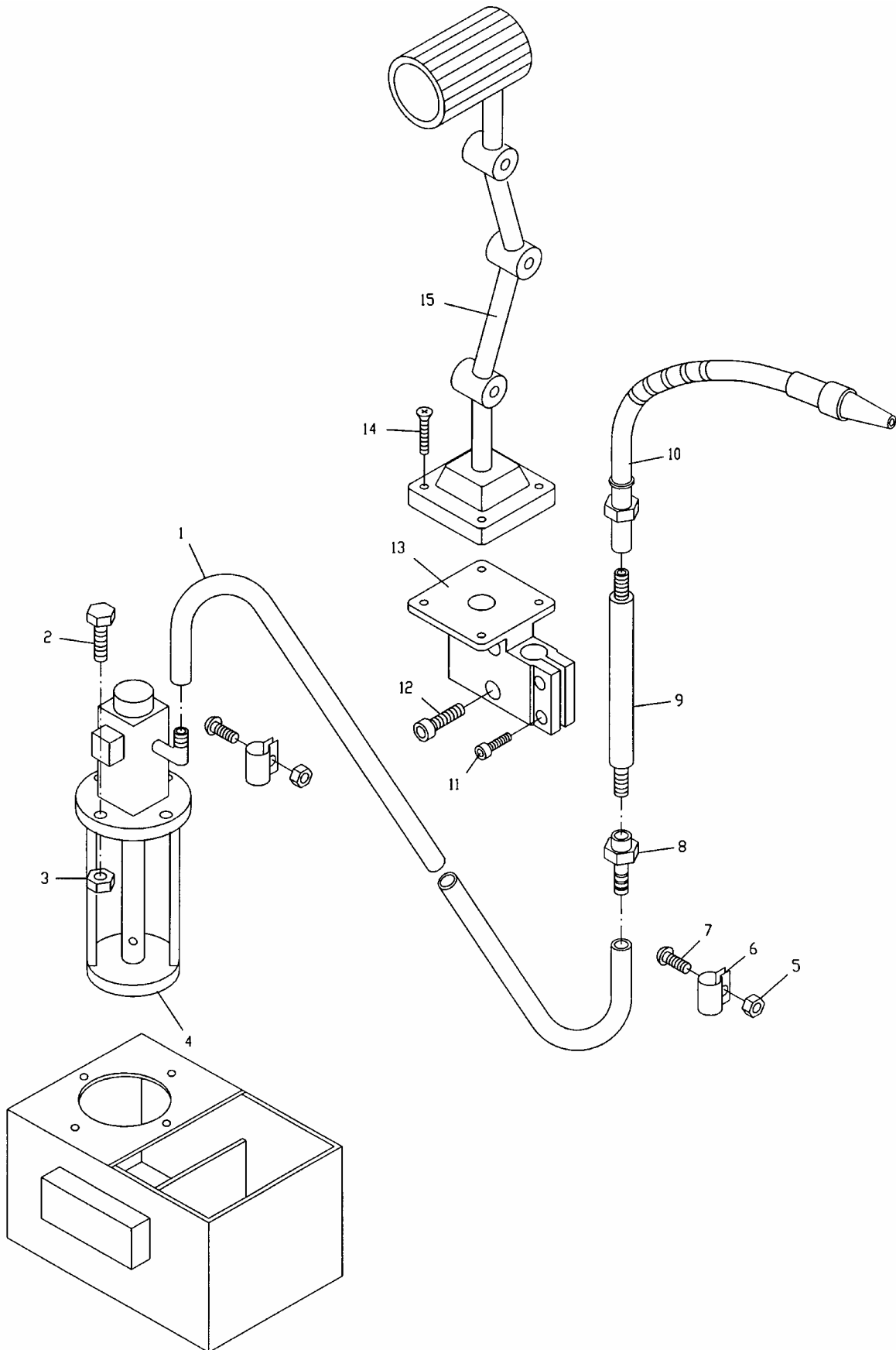

Coolant & Work Light Assembly

| Index No. | Part No. | Description | Size | Qty. |
|-----------|------------|------------------------------------|----------------|------|
| 1 | RT-001A | Rubber Tube (for 1440/1640/1840ZX) | ID 1/2"x1280mm | 1 |
| | RT-001B | Rubber Tube (for 1460/1660/1860ZX) | ID 1/2"x1780mm | 1 |
| | RT-001C | Rubber Tube (for 1880ZX) | ID 1/2"x2280mm | 1 |
| 2 | ZX-CW02 | Hex Cap Bolt | M5x25 | 4 |
| 3 | ZX-CW03 | Hex Nut | 5 | 4 |
| 4 | ZX-CW04E | Coolant Pump | | 1 |
| 5 | ZX-CW05 | Hex Nut | M6 | 2 |
| 6 | ZX-01727 | Clip For Rubber Tube | | 2 |
| 7 | ZX-CW07 | Half Round Head Screw | M6x16 | 2 |
| 8 | ZX-01728 | Fitting | | 1 |
| 9 | ZX-01729 | Flow Pipe | | 1 |
| 10 | ZX-CW10 | Coolant Device | | 1 |
| | ZX-CW10-1 | Coolant Tap | G 3/8" | 1 |
| 11 | TS-1514021 | Hex Socket Cap Screw | M6x16 | 2 |
| 12 | TS-1515051 | Hex Socket Cap Screw | M8x40 | 2 |
| 13 | ZX-CW13 | Lamp Support | | 1 |
| 14 | ZX-S04 | Cross Head Screw | M6x14 | 4 |
| 15 | ZX-CW 15 | Lamp Frame | | 1 |
| | ZX-CW16 | Bulb | 50W, AC24V | 1 |
| | ZX-LA | Light Assy (includes # 13-15) | | |

Micro Carriage Stop

| Index No. | Part No. | Description | Size | Qty. |
|-----------|----------|----------------------|-------|------|
| 1 | ZX-09709 | Dial | | 1 |
| 2 | ZX-MS2 | Pin | B4x8 | 1 |
| 3 | ZX-09708 | Axle | | 1 |
| 4 | ZX-09105 | Stop | | 1 |
| 5 | ZX-03302 | Sign Plate | | 1 |
| 6 | ZX-MS6 | Nail | 3x8 | 2 |
| 7 | ZX-MS7 | Hex Socket Set Screw | M6x12 | 1 |
| 8 | ZX-09106 | Clamping Plate | | 1 |
| 9 | ZX-MS9 | Hex Socket Cap Screw | M8x20 | 2 |

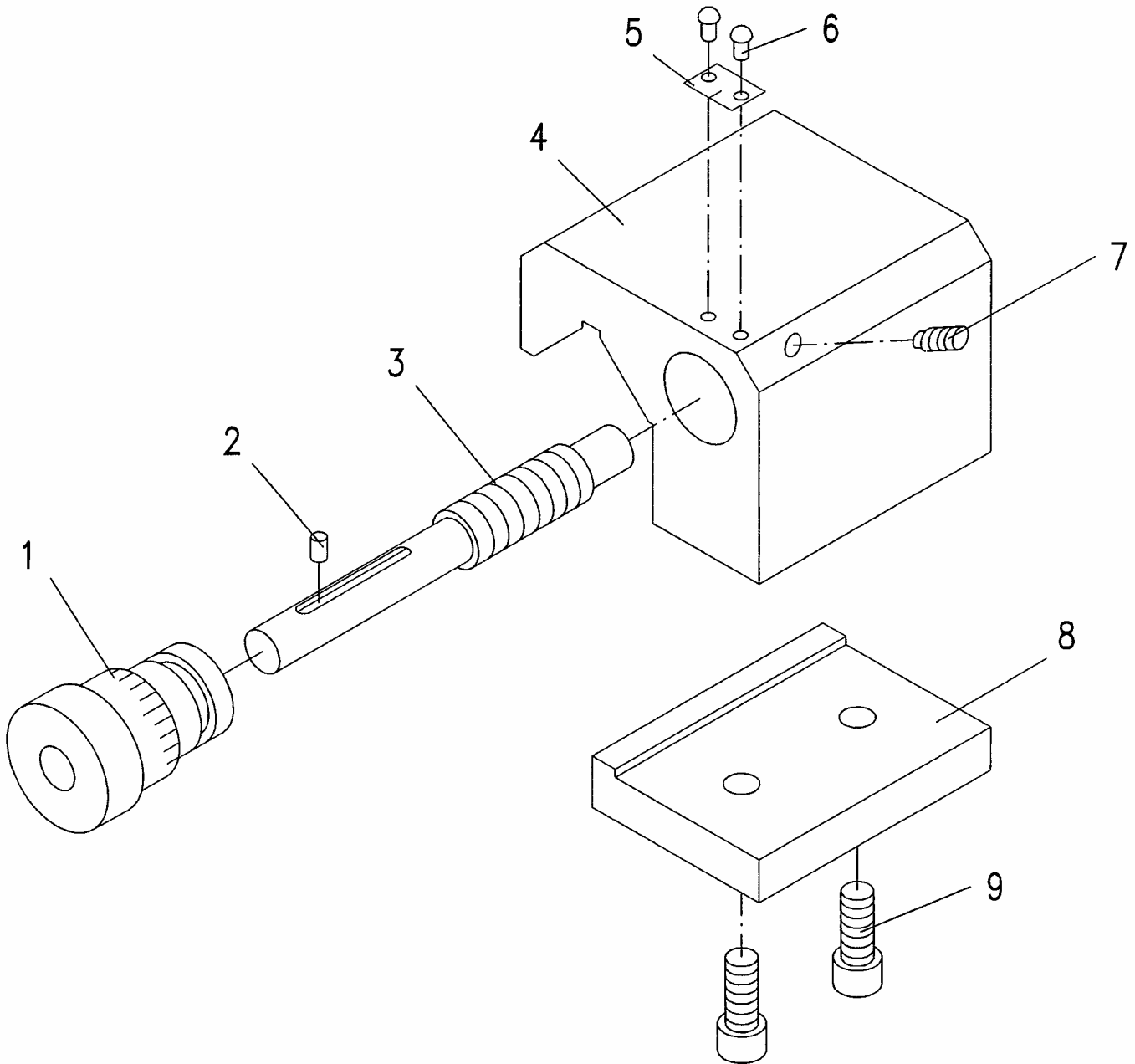

Other Parts

| Index No. | Part No. | Description | Size | Qty. |
|-----------|------------|---------------------------------------|----------------|------|
| 1A | ZX-OP-1A | 3-Jaw Chuck (mounted on lathe) | 10", D1-8 | 1 |
| 1B | ZX-OP-1B | Chuck Wrench | | 1 |
| 2A | ZX-OP-2A | 4-Jaw Chuck | 12", D1-8 | 1 |
| 2B | ZX-OP-2B | Chuck Wrench | | 1 |
| 3 | ZX-OP-03 | 12" Face Plate (for 14"/16" models) | | 1 |
| 3 | ZX-OP-03N | 16" Face Plate (for 18" model only) | | 1 |
| 4 | ZX-OP-04 | Tool Tightening Wrench | | 1 |
| 5 | ZX-OP-05 | Cam Tightening Wrench | | 1 |
| 6 | ZX-OP-06 | Center | | 1 |
| 7 | ZX-OP-07 | MT-4 Live Center (for 14"/16" models) | | 1 |
| 7 | ZX-OP-07N | MT-5 Live Center (for 18" model only) | | 1 |
| 8 | ZX-OP-08 | Morse Reduction Sleeve | | 1 |
| 9 | ZX-OP-09 | Oil Gun | | 1 |
| 10 | ZX-OP-10 | Touch Painting Can | | 1 |
| 11 | ZX-OP-11 | Gap Bridge Pin Driver | | 1 |
| 12 | ZX-OP-12 | Hex Wrench | 2,5,4,5,6,8,10 | 1 |
| 13 | ZX-OP-13 | Double End | | 1 |
| 14 | ZX-OP-14 | Flat Blade Screw Driver | | 1 |
| 15 | ZX-OP-15 | Cross Point Screw Driver | | 1 |
| 16 | ZX-OP-16 | Adjustable Wrench | | 1 |
| 17 | ZX-OP-17 | Round Nut Wrench | | 1 |
| | ZX-14/16TB | Tool Box Complete (not shown) | ZX-14"/16" | |
| | ZX-18TB | Tool Box Complete (not shown) | ZX-18" | |

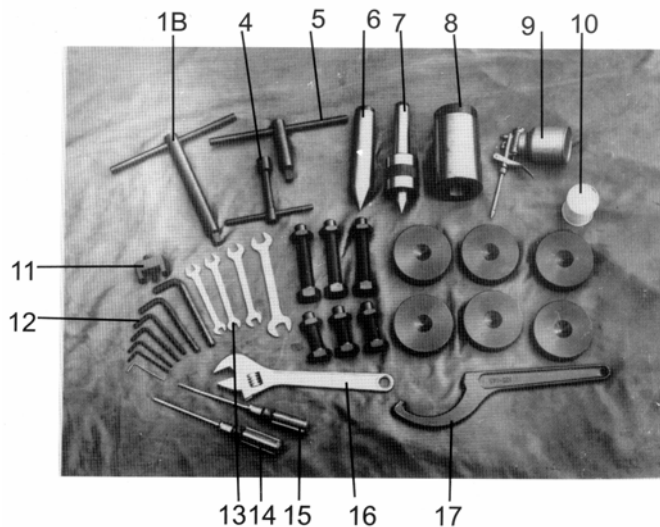
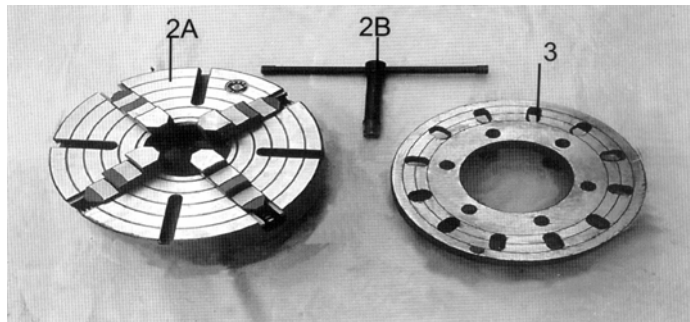

Electric Cabinet

| Index No. | Part No. | Description | Size | Qty. |
|-----------|----------|------------------------------|---------------|------|
| 1 | ZX-SB1E | Jog Button | LAY12-10 | 1 |
| 2 | ZX-SA2E | Coolant Control Button | LAY12-11X/2 | 1 |
| 3 | ZX-SB2E | Emergency Stop | LAY12-01ZS/1 | 1 |
| 4 | ZX-HLE | Power Indicator Light | LAY12-AD/110V | 1 |
| 5 | SQ2SQ3E | Stroke Switch | LXW5-11D1 | 2 |
| 6 | ZX-QF | Master Switch (40A) | D215-40 | 1 |
| 7 | ZX-FU1 | Fuse (3A) | JRT1-16A | 1 |
| 8 | ZX-FU2 | Fuse (2A) | JRT1-16A | 1 |
| 9 | ZX-FU3 | Fuse (2A) | JRT1-16A | 1 |
| 10 | ZX-FU5 | Fuse (2A) | JRT1-16A | 1 |
| | ZX-FB | Fuse Block | | 1 |
| 11 | ZX-QE | Temperature Relay | JW6 | 1 |
| 12 | ZX-KM2E | A.C. Contactor | 3TB40 | 1 |
| 13 | ZX-KAE | A.C. Contactor | 3TB80 | 1 |
| 14 | ZX-KM3E | A.C. Contactor | 3TB43 | 1 |
| 15 | ZX-KM4E | A.C. Contactor | 3TB43 | 1 |
| 16 | ZX-XBE | Copper Plate (for grounding) | | 1 |
| 17 | ZX-XT1E | Wiring Board | JT1 | 1 |
| 18 | ZX-XT2E | Wiring Board | JX0 | 1 |
| 19 | ZX-TCE | Control Transformer | JBK3-100-TH | 1 |
| 20 | ZX-SQ1E | Stroke Switch | LXW5-11N1 | 1 |
| 21 | SQ4E | Stroke Switch | LXW5-11Q1 | 1 |

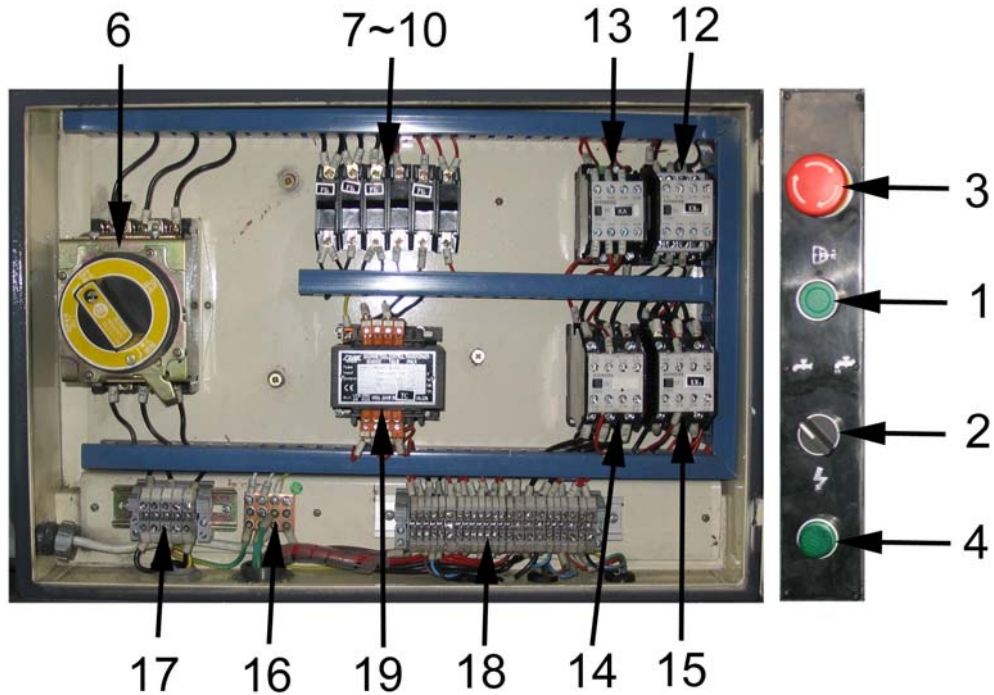

Wiring Diagram

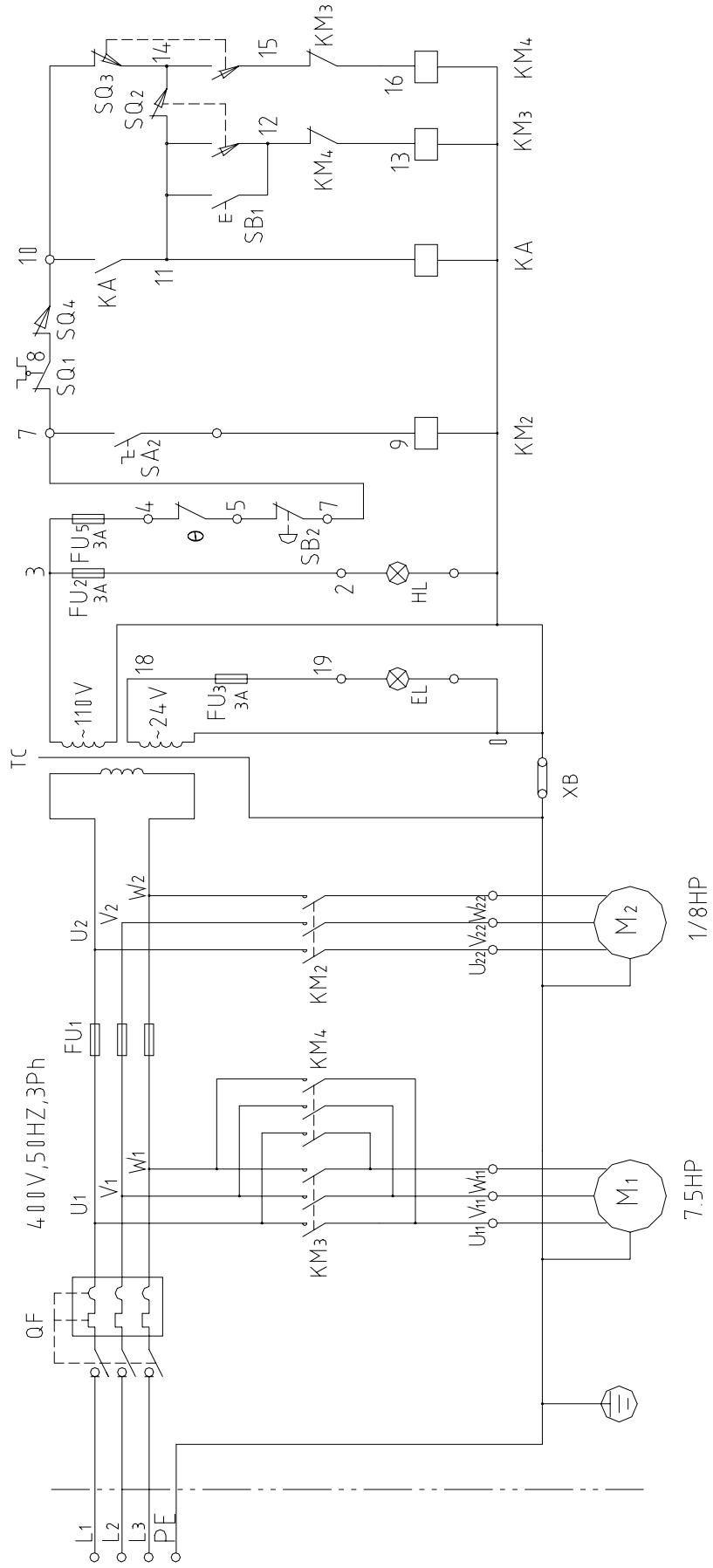

Protecting guards for three rods

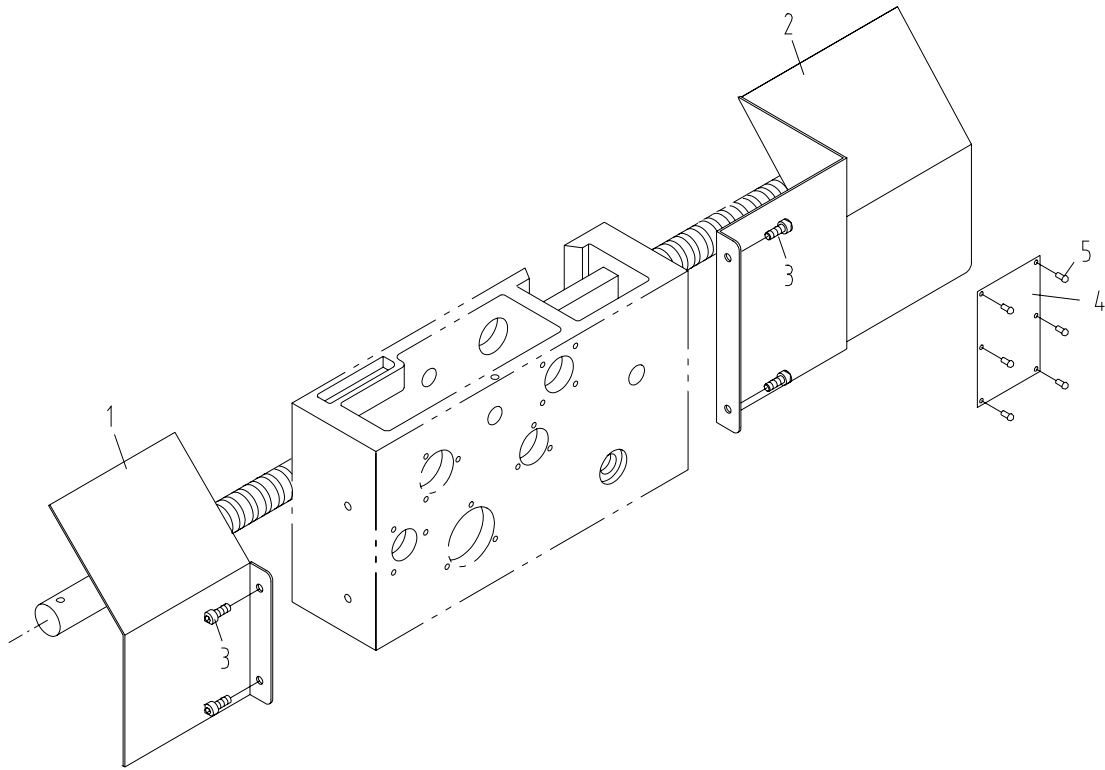

| Index No. | Part No. | Description | Size | Qty. |
|-----------|-----------|-----------------------|------|------|
| 1 | ZX-20701E | Splash Guard | | 1 |
| 2 | ZX-20702E | Splash Guard | | 1 |
| 3 | ZX-P03E | Hex Socket Cap Screw | M5x8 | 4 |
| 4 | ZX-11304E | Thread Chasing Label | | 1 |
| 5 | ZX-P05E | Half Round Head Screw | M3x6 | 6 |

Safety guard cover

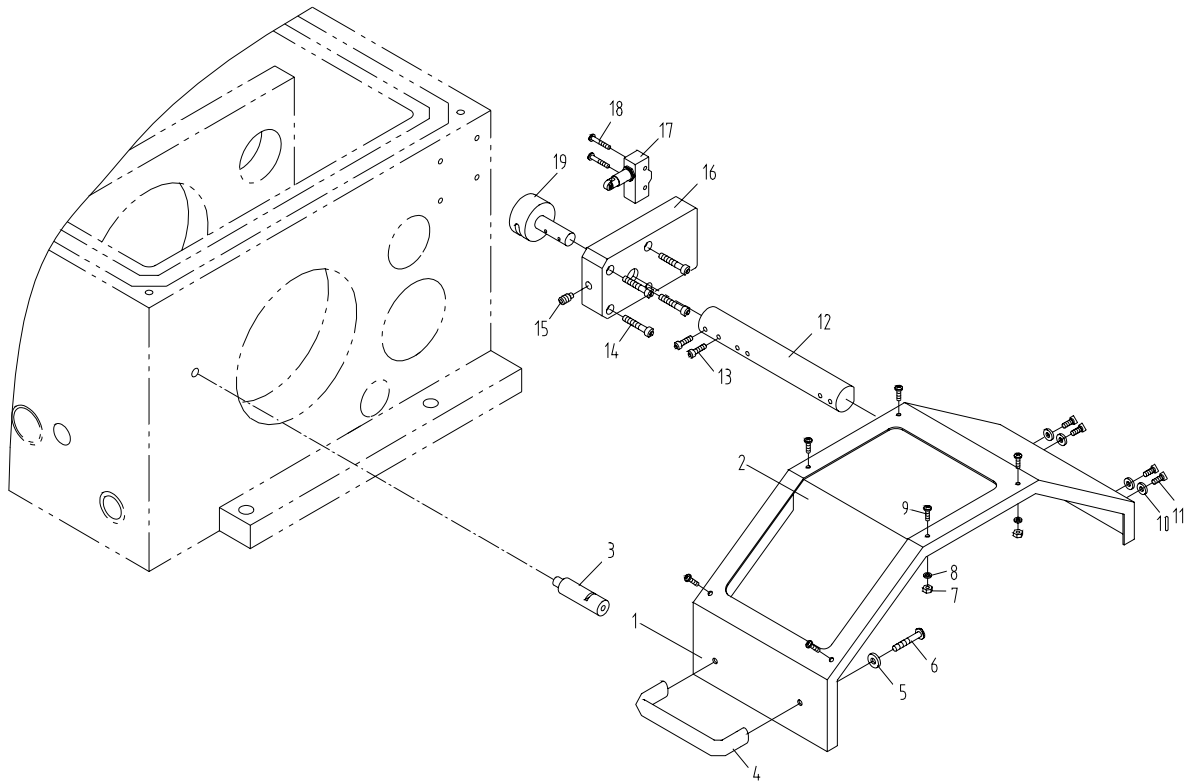

| Index No. | Part No. | Description | Size | Qty. |
|-----------|-----------------|--------------------------------|-----------|------|
| 1 | ZX-19701AE | Protection guard | | 1 |
| 2 | ZX-19501E | Protection guard visual glass | | 1 |
| 3 | ZX-19704E | Fixing rod | | 1 |
| 4 | ZX-S04E | Handle | Z96-6 | 1 |
| 5 | ZX-S05E | Plain washers | 6 | 2 |
| 6 | ZX-S06E | Cross recessed pan head screws | M6x12 | 2 |
| 7 | ZX-S07E | Hexagon thin nuts | M4 | 6 |
| 8 | ZX-S08E | Plain washers | 4 | 6 |
| 9 | ZX-S09E | Cross recessed pan head screws | M4x12 | 6 |
| 10 | ZX-S10E | Plain washers | 5 | 4 |
| 11 | ZX-S11E | Hexagon socket cap head screws | M5x16 | 4 |
| 12 | ZX-19703AE | Rest bar | | 1 |
| 13 | ZX-S13E | Slotted set screws | M5x10 | 2 |
| 14 | ZX-S14E | Hexagon socket cap head screws | M6x35 | 4 |
| 15 | ZX-S15E | Hexagon socket set screws | M8x16 | 1 |
| 16 | GH1440A-19101AE | Switch box | | 1 |
| 17 | ZX-S17E | Stroke switch | LXW5-11Q1 | 1 |
| 18 | ZX-S18E | Slotted pan head screws | M4x25 | 2 |
| 19 | ZX-19702AE | Shaft | | 1 |